

भारत सरकार GOVERNMENT OF INDIA
रेल मंत्रालय MINISTRY OF RAILWAYS
रेलवे बोर्ड RAILWAY BOARD

No.2007/M(N)/204/3.-Part(2)

New Delhi, dated: 24.12.2021

**General Managers
All Indian Railways**

**The Director General
R.D.S.O
Lucknow**

Sub: New Wagon Design Policy

Ref: Procedure of New Wagon Design approvals No WD-02-WDA-2009 (originally issued in 2007) with Amendment in Aug'10 issued by RDSO, Lucknow

In order to expedite the introduction of New Wagon Designs incorporating latest technological advancements on Indian Railways to cater to the emerging need of more efficient and cost effective transportation of existing commodities and expansion of the commodity basket, a New Wagon Design Policy has been framed. Copy of the Policy is enclosed. This Policy may be given wide publicity in the area falling under your jurisdiction.

This Policy is in supersession of existing procedure of New Wagon Design approvals mentioned under reference above. However, New Wagons designs approved and in operation as per the existing procedure (prior to issue of this policy) or Proposal of New Wagon designs already received and under process within the ambit of the existing procedure (prior to issue of this policy), and which have been found acceptable during initial scrutiny by Board, shall continue to be governed/processed as per terms and conditions mentioned in the existing procedure (prior to issue of this policy).

This issues with the approval of CRB & CEO, Member (O&BD), Member (Infra), Member (T&RS) & Member (Finance).

Vivek
24/12/21
(Vivek Mohan)

Director, Mech. Engg. Freight

Encl: As above

Copy forwarded for information to:

- i) Principal Chief Mechanical Engineers, All Indian Railways
- ii) Principal Chief Operation Managers, All Indian Railways
- iii) Principal Financial Adviser, All Indian Railways
- iv) Director General IRIMEE, NAIR, IRITIM, IRICEN, IRIEEN, IRISSET & IRIFM
- v) Managing Director DFCCIL & CRIS
- vi) CMD RITES, IRCON, KRCL & BCL
- vii) President FICCI & CII
- viii) PED (B&S), PED (Track), PED (TI), PED (Signal), RDSO, Lucknow
- ix) Executive Director Standards Wagon, RDSO, Lucknow
- x) Executive Director Track, RDSO, Lucknow
- xi) Executive Director Freight Marketing, Railway Board, New Delhi
- xii) All Wagon Builders in India registered with RDSO
- xiii) All Container Train Operators registered with Indian Railways
- xiv) All leasing companies involved in Freight Wagon Business in India

Vivek
24/12/21
(Vivek Mohan)
Director, Mech. Engg. Freight

Copy for kind information to :

1. Chairman & CEO, Member (O&BD), Member (Finance), Member (Infra), Member (T&RS) and Secretary Railway Board, New Delhi
2. Chief Commissioner of Railway Safety, Ashok Marg, NE Railway Compound, Lucknow, UP
3. AM(TT), AM(C), AM (CE), AM (L&A), AM (Traction), AM (Signal), AM (RE), AM (Plg), AM (F), Adv (PU), PED (Infra), PED(Vig), EDTC(Rates), PEDTT(M), EDTT(S), EDTT(F), ED(Coal), ED (BD), ED (Plg), EDCE (G), EDFs, EDF(X)-II, Railway Board, New Delhi

भारत सरकार GOVERNMENT OF INDIA
रेल मंत्रालय MINISTRY OF RAILWAYS
रेलवे बोर्ड RAILWAY BOARD

New Wagon Design Policy

(Issued vide Railway Board's letter No.2007/M(N)/204/3.-Part(2) dated: 24.12.2021)

Vinik

Contents

1. Objective	1
2. Definitions	1
3. Stages of Approval/Clearance.....	2
4. Details of Stages of Approval/Clearance.....	2
5. Time-Lines for Approval/Clearance by IR	8
6. Payment for NWD approval	9
7. Committee on Wagon Design (CWD).....	10
8. Selection of ISAs:.....	11
9. Maintenance of NWDs.....	12
10. Agreement for New Wagon Design Maintenance	14
11. Inspection.....	14
12. Warranty	14
13. Safety Report	15
14. Obligation in case of Accident of Wagons	15
15. Limitation of Liability.....	15
16. Insurance.....	16
17. Confidentiality & IPR	16
18. Use of NWD by Third Party/IR	17
19. Indemnity.....	18
20. Dispute resolution.....	18
21. Modifications in the Policy.....	18
Annexure A- Guidelines for New Wagon Design (GWD)	19
Annexure A1- Indian Railways Schedule of Dimensions (IRSOD)-2021	65
Annexure B- Payload to Tare ratio of some of the Wagons currently running on IR	130
Annexure B1- Rake Composition of Different types of Wagons on Indian Railways.....	131
Annexure C-Terms & Conditions for Licensing/Providing access to Maintenance Facilityof IR to WD	132
Annexure D- Charge for some of the Unique activities related to Wagon Maintenance.....	134

Vimh

1. Objective

- 1.1. To expedite introduction of new wagon designs incorporating latest technological advancements on Indian Railways to cater to the emerging need of more efficient & cost-effective transportation of existing commodities and expansion of the commodity basket.

2. Definitions

- 2.1. BPC- Brake Power Certificate which is issued after a rake is examined.
- 2.2. CWD- Committee on Wagon Design of IR formed for the purpose of processing of New Wagon Designs being proposed under this policy
- 2.3. CCRS- Chief Commissioner of Railway Safety, Ministry of Civil Aviation.
- 2.4. DLC- Design Loan Charges which are mutually agreed to between WD and third party for use of NWD
- 2.5. Good Industry Practice- The practices, methods, techniques, designs, standards, skills, diligence, efficiency, reliability, and prudence which are generally and reasonably expected from a reasonably skilled and experienced Entity engaged in the same type of undertaking as envisaged under this policy and which would be expected to result in the performance of its obligations by the Entity in accordance with this policy, applicable laws and applicable permits in reliable, safe, economical and efficient manner.
- 2.6. GWD- Guidelines issued by IR for New Wagon Designs being proposed under this policy (enclosed at **Annexure-A & A1**)
- 2.7. IR- Indian Railways
- 2.8. IRS- Indian Railway Standard
- 2.9. ISA- Independent Safety Assessor- An accredited body competent to carry out design review, inspection and testing, duly certifying conformance with prescribed guidelines/standards.
- 2.10. NTRX- Neutral Train Examiner which is part of Neutral Control Organization (NCO) who carries out examination of wagons in IR depots/workshops after Routine Overhaul/Periodic Overhaul/Special Repairs
- 2.11. NWD- New Wagon Design being proposed under this policy

- 2.12. PTR- Payload to Tare Weight ratio- derived by dividing the commodity carrying capacity (in tonnes) of the wagon by the tare weight (in tonnes) of the wagon, one of the indicators of design efficiency of the wagon [PTR of some of the wagons in service on IR is placed at **Annex-B**]
- 2.13. Rake- Standard length freight train comprising varying number of wagons depending upon the length of individual wagon(s) [a list of rakes of different wagons is placed at **Annex-B1**]
- 2.14. RB- Railway Board, Ministry of Railways
- 2.15. RDSO- Research Designs and Standards Organization, Lucknow- the R&D wing of Indian Railways
- 2.16. TLD- Track Loading Density in tonnes/meter wagon length over coupler
- 2.17. WD- Wagon Designer, the party who is proposing New Wagon Design under this policy. WD can be an individual, private/public limited company, joint venture or a partnership firm
- 2.18. ZR- Zonal Railway- currently there are 17 Zonal Railways on IR (including Kolkata Metro)

3. Stages of Approval/Clearance

- 3.1. **Stage-I**- Preparation & Submission of Proposal of New Wagon Design (NWD) by the Wagon Designer (WD)
- 3.2. **Stage-II**- In-principle Clearance by the Committee on Wagon Design (CWD)
- 3.3. **Stage-III**-Detailed Designing of the proposed NWD
- 3.4. **Stage-IV**-Manufacturing of two Prototype Wagons
- 3.5. **Stage-V**- Static and Dynamic testing of Prototype Wagons
- 3.6. **Stage-VI**- Sanction & Manufacturing of two rakes of NWD for field service testing
- 3.7. **Stage-VII**- Field Service testing of 2 rakes of NWD
- 3.8. **Stage-VIII**- Final Clearance for unrestricted introduction of NWD on IR

4. Details of Stages of Approval/Clearance

4.1. Stage-I- Preparation & Submission of Proposal of New Wagon Design by the Wagon Designer (WD)

- 4.1.1. WD shall prepare a proposal for a New Wagon Design clearly bringing out latest technological advancements proposed in the design, commodity(ies) for which it will be used, proposed for pan India operation or specific routes, business potential, how it will make the transportation of existing commodities more efficient & cost effective and/or expand the commodity basket, etc.
- 4.1.2. Modification of the existing wagon designs owned by IR can also be proposed by WD, which will be considered as NWD. However, the modifications proposed should be such as to make the existing design more efficient for transportation of existing commodities/new commodities and which should be clearly spelt out in the proposal.
- 4.1.3. A concept design of proposed New Wagon shall be prepared by the WD, duly complying with the relevant Guidelines for Wagon Design (GWD).
- 4.1.4. Details of use of IRS components, if any, in the NWD.
- 4.1.5. Proposal for NWD for use only on Indian Railways Track (including DFCs) will be covered by this policy.
- 4.1.6. WD shall also submit an undertaking confirming unconditional acceptance of all the terms and conditions included in this policy.
- 4.1.7. WD shall also furnish summary of the information submitted, duly indexed, giving reference to the various clauses of this policy and compliance of relevant GWD.
- 4.1.8. Contact details of one Nodal person for interaction with CWD shall also be submitted by WD in the proposal.
- 4.1.9. WD shall submit proposal of NWD along with Concept Design through an online portal for scrutiny by CWD.

4.2. Stage-II- In-principle Clearance by CWD

- 4.2.1. Proposal of NWD shall be scrutinized by CWD mainly for its broad suitability in meeting the objective of this policy and broad compatibility with operational requirements of IR.

4.2.2. A presentation shall be given by the WD to members of CWD, bringing out salient features of proposed wagon design and how it is meeting the objective of this policy, within 15 days of submission of the proposal.

4.2.3. After presentation, in-principle clearance shall either be granted to the WD to go ahead with the further design work or denied or commented upon and communicated to WD accordingly, through the online portal.

4.3. Stage-III-Detailed Designing of the proposed NWD

4.3.1. After receiving in-principle clearance, WD will proceed with the detailed designing work of proposed wagon, duly complying with the relevant GWD.

4.3.2. A tentative plan for undertaking further design, manufacturing and testing work shall be submitted by the WD to CWD through online portal, within 15 days of receiving the in-principle clearance.

4.3.3. Selection of Independent Safety Assessor(s) (ISAs) shall be done by WD and advised to CWD along with all the necessary documents as mentioned in clause 8.2 through the online portal within 15 days of receiving the in-principle clearance.

4.3.4. A detailed Quality Assurance Plan (QAP) for stage inspection and final inspection of prototype wagons shall be prepared by WD, duly complying with relevant GWD.

4.3.5. The detail design of the proposed wagon developed by WD shall be certified by ISA for compliance with GWD, standards/parameters proposed by the WD & validated also.

4.3.6. The detail design of the proposed wagon along with QAP and certificate of ISA shall be submitted by WD to CWD through online portal and a presentation on the same shall also be given by WD for better appreciation and comments by members of CWD, if any, for the consideration of WD, within 15 days of the submission of documents.

4.4. Stage-IV-Manufacturing of two Prototype Wagons

4.4.1. After presentation to CWD and suitably incorporating comments of members of CWD, as deemed fit, manufacturing of two prototype wagons shall be undertaken by the WD either in-house or through outsourcing in India or abroad.

4.4.2. Stage inspection of prototype manufacturing shall be undertaken by ISA as per QAP prepared by WD and in accordance with relevant GWD. After completion of

manufacturing, final inspection of prototype wagons shall be done and duly certified by ISA, including certification of compliance with GWD and standards/parameters proposed by the WD.

- 4.4.3. Relevant documents of prototype wagons along-with certificate of ISA shall be submitted by WD to CWD through online portal.
- 4.4.4. Final prototype wagons shall be inspected by member(s) of CWD or their authorized representative(s), for better appreciation and comments of member(s), if any, for the consideration of WD. During this inspection, a detailed presentation on the prototype wagons shall also be given by WD. This process shall be completed within 30 days of receipt of documents of manufactured prototype wagons by CWD.
- 4.4.5. For dynamic trial of prototype wagon and its movement from place of manufacturing to nominated test site, WD will submit request to CWD, through online portal. In case movement of prototype wagon is planned by Road, WD will only submit request for dynamic trial at nominated test site.
- 4.4.6. CWD will advise RDSO to issue necessary authorization for dynamic trials and movements, as applicable, including obtaining sanction of concerned Zonal Railway(s). This process shall be completed within 60 days of receipt of the request of WD.

4.5. Stage-V- Static and Dynamic testing of Prototype Wagons

- 4.5.1. After inspection of two prototype wagons and suitably incorporating comments of members of CWD, as deemed fit, static testing on one prototype wagon shall be undertaken by ISA at the manufacturer's place or at mutually agreed place, duly complying with the relevant guidelines of GWD.
- 4.5.2. Necessary facilities for carrying out static tests shall be made available by the WD to ISA.
- 4.5.3. Dynamic testing shall be undertaken by ISA on second prototype wagon, duly complying with the relevant guidelines of GWD. In case movement is planned by Rail, charges for hauling of prototype wagon to nominated test site for dynamic trials have been included in the payment made by WD to IR, as mentioned in para 6.1 (IV).
- 4.5.4. Necessary facilities for dynamic testing shall be made available by WD to ISA. However, hiring of oscillograph car and other equipments unique to IR can also be done from RDSO by WD at published rates, for which a request shall be submitted by WD to CWD, through online portal, for onward submission to Executive Director/Testing/RDSO. RDSO will make

Vimsh

best efforts to make available the requested resources within 45 days from the date of receipt of request by CWD.

- 4.5.5. Charges for hauling the test train- prototype wagon and oscillograph car during dynamic trials have been included in the payment made by WD to IR, as mentioned in para 6.1 (IV).
- 4.5.6. WD shall keep the CWD apprised, through online portal, on the planned dates for undertaking static & dynamic testing of prototype wagons.
- 4.5.7. Authorized representative(s) of RDSO, duly nominated by CWD, will also be associated with Static & Dynamic testing of prototype wagons. However, no approval/endorsement of representative(s) of RDSO shall be required.
- 4.5.8. After satisfactory completion of static and dynamic testing, duly witnessed & certified by ISA, including certification of compliance with GWD and standards/parameters proposed by the WD, proposal shall be submitted by WD, through online portal, along with all the relevant documents (results of static & dynamic trials, certification of ISA, maintenance manual, etc.), to CWD for processing sanction of NWD for going ahead with the manufacturing of two rakes for field service testing.

4.6. Stage-VI- Sanction& Manufacturing of two rakes of NWD for field service testing

- 4.6.1. After scrutiny of documents submitted and being found satisfactory, CWD will advise RDSO to process to obtain sanction of Railway Board for introduction of NWD for operation on IR, through CCRS. During this process, a Final Speed Certificate shall be issued by RDSO, which will be submitted by RDSO to CCRS for recommending to RB for sanction. In RB, EDCE/G being the nodal officer, shall process for the sanction of NWD based on the advise of CWD, Final Speed Certificate of RDSO & recommendation of CCRS and issue necessary sanction. This whole process, from the time of submission of request by WD to issue of sanction, shall be completed within 90 days of receipt of request by WD.
- 4.6.2. After issue of sanction by RB, WD can start manufacturing two rakes of NWD either in-house or through outsourcing. In either case, the manufacturing has to be done in India. However, special components which are not available in India can be imported.
- 4.6.3. Proposed maintenance regime of the NWD shall also be prescribed by the WD at this stage.
- 4.6.4. During manufacturing, periodic inspection shall be undertaken by ISA, as per relevant guidelines of GWD.

- 4.6.5. Inspection certificate of the manufactured wagons shall be issued by ISA.
- 4.6.6. After communication of sanction by RB, concerned ZRs shall process issue of a Joint Safety Certificate by concerned Principal Head of Departments (PHODs) and sanction by the General Manager. ZRs will communicate the sanction within 60 days of issue of sanction by RB. Progress will be monitored by CWD.
- 4.6.7. A maintenance manual of NWD will be issued by the WD duly mentioning the maintenance regime with details of facilities required for maintenance, methodology to carry out maintenance and special repairs, necessary drawings required for maintenance, spare parts catalogue, etc.
- 4.6.8. An operating manual/instructions of NWD will be issued by the WD duly mentioning the special procedure (different from operation normally carried out on IR, in same category of wagons) of operation of NWD like: Loading/Unloading of commodities, opening and closing of doors, any other feature. A pictorial diagram depicting such special operation shall also be issued and provided on wagon at a suitable place having good visibility.
- 4.6.9. For special trials like Emergency braking distance/Coupler force/controllability, as mentioned in GWD, WD will submit request, through online portal, within 60 days of sanction of RB. Charges for hauling the test train during special trials and movement of test train to nominated test site have been included in the payment made by WD to IR, as mentioned in para 6.1 (VI).
- 4.6.10. CWD will advise RDSO to issue necessary authorization for such trials, including obtaining sanction of concerned Zonal Railway(s). This process shall be completed within 60 days of receipt of the request of WD.

4.7. Stage-VII- Field Service testing of 2 rakes of NWD

- 4.7.1. Two (2) rakes duly inspected by ISA will be inducted for test and trials (at least one full rake to be introduced at a time).
- 4.7.2. Special trials like Emergency braking distance/Coupler force/controllability shall be undertaken by ISA, as per relevant guidelines of GWD, on one rake of NWD, on nominated section of IR track.
- 4.7.3. WD shall intimate the CWD of planned date of such trials at least 30 days in advance, through online portal.

- 4.7.4. Authorized representative(s) of RDSO, duly nominated by CWD, will also be associated with the Special trials.
- 4.7.5. Results of such trials, duly certified by the ISA, including certification of compliance with GWD and standards/parameters proposed by the WD, shall be submitted, through online portal, by the WD to CWD for requesting clearance for operation, as applicable.
- 4.7.6. If the results are found satisfactory, CWD will advise RDSO to issue necessary authorization and obtaining sanction of concerned Zonal Railway(s), for the operation, as applicable. This process shall be completed within 75 days of receipt of the request of WD.
- 4.7.7. During field service testing, periodic inspection shall be undertaken by ISA, as per relevant guidelines of GWD.
- 4.7.8. After revenue service of 2 rakes for 50,000 km each (likely to be earned in approx. 180 days), detailed inspection will be undertaken by ISA on all wagons in order to assess the efficacy of design and manufacture of NWD.

4.8. Stage-VIII- Final Clearance for unrestricted introduction of NWD on IR

- 4.8.1. WD will submit, through online portal, report of field service testing of two rakes, including periodic & final inspection reports of ISA, including certification of compliance with GWD and standards/parameters proposed by the WD, to CWD for final clearance.
- 4.8.2. After scrutiny of the reports submitted, final clearance for unrestricted introduction shall be granted by CWD. This will be completed within 15 days of receipt of the request of WD.

5. Time-Lines for Approval/Clearance by IR

5.1. Time-Lines for Approval/Clearance shall be as under, provided no queries are involved:

Stage	By					
	(In number of days from date of submission of request by WD through online portal)					
	CWD	RDSO	ZRs	CCRS	RB	Remarks
I- Submission of Proposal to CWD NWD (CI 4.1.9)	D1					
II- In-principle clearance by CWD (CI 4.2.2 & 4.2.3)	<u>D2=</u> <u>D1+15</u>					
III (for CI 4.3.6)- Presentation on	<u>D3+15</u>					D3- date of submission of detail design documents of proposed wagon by WD to CWD

Vink

Stage	By					
	(In number of days from date of submission of request by WD through online portal)					
	CWD	RDSO	ZRs	CCRS	RB	Remarks
detailed design to CWD						
IV (for CI 4.4.4)- Inspection & Presentation on manufactured prototype to CWD	<u>D4+30</u>					D4- date of submission of documents of manufactured prototype by WD to CWD
IV (for CI 4.4.6)- Authorization for movement by Rail, as applicable, and for Dynamic Testing		D4A+30	D4A+ 60			D4A- date of submission of request by WD to CWD
VI (for CI 4.6.1)- Sanction of RB for introduction of NWD for operation on IR	<u>D6+15</u>	<u>D6+45</u>	*60	<u>D6+ 75</u>	<u>D6+ 90</u>	D6- date of submission of request for processing sanction by WD to CWD
VI (for CI 4.6.10)- Authorization for special trials		D6A +30	D6A +60			D6A- date of submission of request for authorization for special trials by WD to CWD
VII (for CI 4.7.6)- Authorization for Operation	D7+15	D7 +45	D7 +75			D7- date of submission of request for authorization for Operation by WD to CWD
VIII (for CI 4.8.2)- Final clearance for unrestricted introduction	<u>D8+15</u>					D8- date of submission of request for final clearance by WD to CWD

Note:

1. Time shown in bold & underline will be the period CWD/RDSO/CCRS/ZRs will normally take for an action. Time in other activities shall be in parallel and will not hamper progress of WD/Operation of wagons.
2. * This will not affect the timeline, as operation of NWD shall be started only when at least one rake is manufactured by WD and inspected by ISA.

6. Payment for NWD approval

6.1. Following Payment shall be made by the WD through online Portal:

Stage	Amount (in lacs of ₹)	Remarks
I-Submission of Proposal of NWD (CI 4.1.9)	5	At the time of submission of proposal to CWD
III- Submission of detail design to CWD (CI 4.3.6)	15	At the time of submission of proposal to CWD

Stage	Amount (in lacs of ₹)	Remarks
IV-Authorization for movement by Rail, as applicable, and for Dynamic Testing (CI 4.4.5) (includes charges for hauling the test train during dynamic trials and movement of prototype wagon to nominated test site, as applicable)	30 (15, if movement is planned by Road)	At the time of submission of request to CWD
V-for Sanction for going ahead with the manufacturing of two rakes for field service testing (CI 4.5.8) (includes charges for providing access to IR's maintenance facilities during field service trials)	25	At the time of submission of proposal to CWD
VI-for Authorization for special trial(s) (includes charges for hauling the test train during special trials and movement of test train to nominated test site) (CI 4.6.9)	20	At the time of submission of request to CWD
VII-for Authorization for permitting Operation (CI 4.7.5)	5	At the time of submission of request to CWD
VIII-final clearance for unrestricted introduction for operation of NWD (CI 4.8.1)	20	At the time of submission of request to CWD

- 6.2. These rates can be reviewed by IR after every five years.
- 6.3. If the proposal is found unsuitable or is withdrawn by the WD, payment already made to Railways shall not be refunded.
- 6.4. Any other cost incidental to approval of NWD or the maintenance of NWDs and not covered by this policy shall be borne by the WD.

7. Committee on Wagon Design (CWD)

- 7.1. A Committee on Wagon Design (CWD) will be constituted by Ministry of Railways for the purpose of processing of New Wagon Designs proposed under this policy.

7.2. It will consist of six members, as follows: -

- a) Executive Director/Wagon/RDSO
- b) Executive Director/Track/RDSO
- c) Executive Director/Freight Marketing/RB
- d) Two technical experts having relevant domain expertise from Industry, to be rotated every three years- one each to be nominated by Confederation of Indian Industry (CII)/Federation of Indian Chambers of Commerce & Industry (FICCI)
- e) Executive Director Mechanical Engg./Freight/RB (Convenor)

7.3. All members of CWD will sign a Non-Disclosure Agreement (NDA) with regard to keeping the proceedings of the Committee and information acquired during interaction with WDs confidential and also submit a declaration regarding non-conflict of Interest of any of the Members of CWD with such an initiative of development of NWD.

8. Selection of ISAs:

8.1. WD can select an ISA, who fulfills the following Requirements:

- 8.1.1. ISA can be an individual or a Partnership firm or a Company or a Joint Venture registered under the relevant applicable laws.
- 8.1.2. ISA carrying out design review work should be an accredited assessment body under **ISO/IEC 17065** (Conformity assessment — Requirements for bodies certifying products, processes and services) for Rolling Stock
- 8.1.3. ISA carrying out Inspection work should be an accredited assessment body under **ISO/IEC 17020** (Conformity assessment — Requirements for the operation of various types of bodies performing inspection) for Rolling Stock
- 8.1.4. ISA carrying out testing work should be an accredited assessment body under **ISO/IEC 17025** (General requirements for the competence of testing and calibration laboratories) for Rolling Stock
- 8.1.5. Accreditation of ISA with appropriate scope shall be from a national/foreign **accreditation body** that is member of one of the following accreditation forums and should have been

admitted to its MLA/MRA (Multilateral recognition arrangement) program with appropriate scope.

- a) International Accreditation Forum (IAF)
- b) European Co-operation for Accreditation (EA)
- c) Pacific Accreditation Cooperation (PAC)

8.1.6. ISA should have successfully completed at least one project of rolling stock (locomotives, passenger carrying coaches, electric/ diesel multiple units, railway wagons) covering the activities of design review and/or inspection and/or testing, in accordance with laid down guidelines, over preceding ten years (from the year of engagement).

8.1.7. At least 25 number of such rolling stock (locomotives, passenger carrying coaches, electric/diesel multiple units, railway wagons) should have successfully completed two years of operation or earned 100,000 km, whichever is earlier.

8.1.8. ISA should not have been blacklisted by any organization or penalized for poor quality work or abandoned any work over preceding 10 years from the date of issue of EOI. An undertaking to this effect shall be submitted by the ISA, duly certified by their Company Secretary/Authorized person, as applicable.

8.1.9. Only one ISA can be selected by WD if it fulfills all the requirements laid down in clauses 8.1.1 to 8.1.8. If not, more than one ISA can also be selected by the WD.

8.1.10. Necessary documents/ Certificates in support of the compliance of clauses 8.1.1 to 8.1.8 above shall be provided by ISA with name, address, phone and email of the contact person signing the document/certificate.

8.2. While intimating the name of selected ISA(s) to CWD, as mentioned in clause 4.3.3, all necessary documents in support of the fulfillment of laid down requirements specified in clause 8.1 shall also be submitted.

9. Maintenance of NWDs

9.1. Maintenance of wagons shall be undertaken by WD himself or through a third party. However, complete responsibility in either case will rest with the WD. However, 1 year after POH of last wagon of initial two rakes, WD will have the option to offer the maintenance of

Vimh

NWDs to IR, on same terms and conditions as prevailing for maintenance of privately owned wagons on IR.

- 9.2. WD will establish a maintenance depot(s) at suitable location(s) for undertaking various maintenance schedules, as prescribed by him. However, for some activities unique to Wagons such as wheel turning arising during course of maintenance, assistance from IR can be sought on chargeable basis, till such facilities are created by WD. Charges for such unique activities are given in **Annexure-D**. These charges can be reviewed after every 5 years.
- 9.3. Connectivity to the maintenance depot(s) shall be provided by IR at the cost of WD as per extant policy.
- 9.4. IR may also license/provide access to one of its maintenance facilities to WD for maintenance of the NWD manufactured by WD on payment of prescribed charges and other terms & conditions placed at **Annexure-C**.
- 9.5. IR shall provide access to IR's maintenance to WD during field service testing of NWD. Charges for the same have been included in the payment made by WD to IR, as mentioned in para 6.1 (V).
- 9.6. WD will employ competent manpower having prior experience in maintenance of wagons in accordance with Good Industry Practices.
- 9.7. After examination of wagon/rake, a fitness certificate shall be issued by the WD. On this basis, final BPC shall be issued by C&W Staff of Railway, when the rake is inducted into commercial operation.
- 9.8. NTXR will undertake examination of wagons after major schedule maintenance (ROH/POH) is done by the WD or its authorized third party.
- 9.9. IR shall be responsible for bringing back wagons for maintenance to the nominated depot/place within prescribed time, as agreed to between WD and IR. Failure to do so will attract token penalty of Rs 100/- per wagon per day on concerned ZR.
- 9.10. No additional charges shall be levied by IR for movement/shunting required for maintenance of NWDs.
- 9.11. For any unscheduled maintenance which may be required to be carried out outside the nominated maintenance facilities of WD, necessary assistance from IR can be provided, on best efforts & chargeable basis.

- 9.12. Pricelist of Spare parts of NWD will be published by the WD which will be updated every three years. However, sum total of cost of all the components of the wagon shall not be more than the cost of the wagon, with a markup of 30% for taking care of procurement, storage & transportation cost. This will be utilized in case NWD or its assemblies/components are procured by any entity other than WD.
- 9.13. If the NWD is procured by a third party, then the third party will have to get the maintenance done through WD, as per terms and conditions mutually agreed to between the parties.
- 9.14. If the NWD is procured by IR, then IR will have the option to carry out the maintenance of NWDs on its own or get it done through WD on mutually agreed terms and conditions.
- 9.15. If maintenance of NWDs procured by IR is carried out on its own, then all information required for carrying out maintenance shall be provided by WD to IR, which will include but not limited to: Necessary drawings, Maintenance regime with methodology, Tools, plants, fixtures, etc., required, procurement specification of spare parts and special tools and plants with list of sources, etc.

10. Agreement for New Wagon Design Maintenance

- 10.1. After the issue of clearance of unrestricted introduction of NWD and prior to its regular induction for commercial operation, an agreement shall be signed between Chief Rolling Stock Engineer/Freight of the concerned Zonal Railway(s) and WD to ensure proper maintenance of wagons and associated safety protocol.
- 10.2. Agreement should be signed within three months of submission of request by WD.
- 10.3. Standard format for agreement shall be issued by CWD.

11. Inspection

- 11.1. IR reserves the right to inspect the wagons or wagon maintenance depot through its authorized representatives any time and at any stage.
- 11.2. Necessary corrective action shall be taken by the WD to address the deficiency(ies) pointed out, if any, during such inspections.

12. Warranty

- 12.1. WD shall be entirely responsible for the design, construction and efficient performance of the wagon, notwithstanding any sanction/approval, and will comply with the warranty for any defect for a period of six years from the date of commissioning of the wagon. It will be

Vimh

applicable only if any entity, other than WD, procures the NWD or its assemblies/parts developed by the WD.

- 12.2. Epidemic Defect Warranty- If any identical defect or deficiency occurs in a component in more than 20% of NWDs, over a rolling period of three years over the maintenance of NWD, WD shall be obligated to replace all such items (which have not failed) in the remaining wagons within six months (if maintenance is undertaken by any entity other than the WD).

13. Safety Report

- 13.1. WD will implement necessary measures for ensuring safety of wagons and the personnel engaged for its upkeep.
- 13.2. An Annual Safety report bringing out incidences during the preceding year, affecting safety or having potential for affecting safety of wagons and personnel employed by WD, and corrective and preventive action taken, shall be brought out and submitted to CWD, through online portal, within 60 days of the anniversary of the commercial operation of the wagons.
- 13.3. Safety report shall include number of wagons inducted into service, with details of commissioning of individual wagons, issues faced (including those not affecting safety), corrective and preventive action taken, resources (manpower, infrastructure, etc.) employed for maintenance of wagons.

14. Obligation in case of Accident of Wagons

- 14.1. If such wagons are involved in an accident as a result of commission or omission on part of WD resulting in damages or condemnation of wagons, WD will bear cost of damages caused to the infrastructure of IR and also pay compensation to IR for the damages and the costs incurred in clearance of NWD rake & railway line or get it cleared at his own cost.
- 14.2. If responsibility of such an accident is ascribed to Railways, then IR will compensate the WD, the cost incurred on such repairs of NWDs. In case of condemnation of such wagons, the depreciated value minus scrap value will be paid by the Railways.
- 14.3. Decision of Railway Administration regarding fixing of responsibility of accident shall be final. However, views of the wagon designer will also be considered by the competent authority

15. Limitation of Liability

- 15.1. The liability of one party towards the other party for any damages or compensation of any nature whatsoever shall not exceed cost of one rake and the locomotive hauling such rake. However, this shall not include any liabilities in respect of third parties.

15.2. Neither party shall be liable to the other party for any loss of profit or for any other indirect or consequential damages or losses that may be suffered during course of operation or maintenance.

16. Insurance

16.1. WD will take insurance of such maximum sum as may be necessary to or prudent in accordance with Good Industry Practice.

16.2. WD shall also effect and maintain such insurances as may be necessary for mitigating the risks that may devolve on IR as a consequence of any act of commission or omission of the WD.

16.3. Insurance cover shall include but not limited to the following:

- a) Loss, damage or destruction of wagons or its maintenance facilities
- b) Comprehensive third-party liability insurance for life, goods or property including injury to or death of personnel of IR or other, arising from any accident at maintenance depot(s) or on account of any negligence of WD or a defect or deficiency in Wagon
- c) General liability arising out of the agreement signed with IR
- d) Workmen's compensation insurance; and
- e) Any other insurance that may be necessary to protect the WD and its employees, including the force majeure events that are insurable but not covered in items a) to d) above

16.4. Evidence of having taken Insurance Cover shall be provided by the WD to CWD within 15 days of sanction for manufacturing of two rakes of NWD.

17. Confidentiality & IPR

17.1. The technical information submitted to CWD under this design approval policy shall not be disclosed or published by CWD to any third party, without the prior written consent of the WD. Similarly, WD shall not disclose or publish technical details of any design provided by IR to any third party without prior approval of CWD.

17.2. The WD shall confirm that the proposed wagon design is neither wholly nor partly, a copy of any of the wagon designs of any other firm/entity/railway. In case, the proposed wagon design is based partly or wholly on design of any other firm/entity/railway, the permission

from that firm/entity/railway shall be furnished by the WD along with the concept design proposal.

17.3. All documents to be submitted by WD must contain the following declaration:

"This document and its contents are the property of M/s XYZ (Name of the vendor) or its subsidiaries. This document contains confidential proprietary information. The reproduction, distribution, utilization or the communication of this document or any part thereof, without express authorization of the owner is strictly prohibited. Offenders will be held liable for the payment of damages. CWD is granted right to use, copy and distribute this document for the limited internal use of new wagon design approval, operation and maintenance to the concerned persons only."

17.4. WD must submit undertaking as under:

"Indian Railways shall not be responsible for infringement of patent rights arising due to similarity in design, manufacturing process, use of similar components in the design & development of this item and any other factor not mentioned herein which may cause such a dispute. The entire responsibility to settle any such dispute(s)/matter(s) lies with the WD. Details/design/documents given by them are not infringing any IPR and they are responsible in absolute and full measure instead of railways for any such violations. Data, specifications and other IP as generated out of interaction with railways shall not be unilaterally used without the consent of IR and right of IR on such IP is acceptable to them."

17.5. If at any stage, any IPR violation/infringement by WD is established with respect to the proposed wagon design, any approval granted to WD by IR shall stand withdrawn and IR will not accept any case of design approval from such WD for the next 10 years, from the date of withdrawal of approval. In addition, entire initial deposit or any remainder thereof, paid by the WD to IR, shall be forfeited.

17.6. IR shall not use any of the proprietary information, provided by WD, for any purpose other than the approval of the wagon design. Also, IR shall not use such information for design of a wagon.

17.7. WD shall not use any of the proprietary information provided by IR for use overseas without express approval of IR, on mutually agreed terms and conditions.

18. Use of NWD by Third Party/IR

18.1. WD can authorize a third Party to manufacture the NWD on basis of DLC to be mutually agreed between the parties. However, in case any IRS components have been used in the NWD, DLC for such components shall not be charged by the WD from the third party.

18.2. After observing the field performance of the NWD, IR shall have the option to procure and operate NWD or its assemblies/components, which suit IR's requirement, without paying any DLC to WD.

19. Indemnity

19.1. WD shall at all times indemnify IR against all claims which may be made in respect of the new wagon design for infringement of any right protected by patent, registration of designs or trademark or due to design deficiency.

20. Dispute resolution

20.1. **Mediation:** In the event of any Dispute between the Parties, either party may call upon a mutually accepted person to mediate and assist the Parties in arriving at an amicable settlement thereof. Failing mediation by such person or without the intervention of such person, either party may require such Dispute to be referred to the Additional Member (Mechanical Engineering), Railway Board for amicable settlement.

20.2. **Arbitration:** Any dispute which is not resolved amicably by Mediation, shall be resolved through Arbitration & Reconciliation Act, 1996 as amended by the Arbitration and Conciliation (Amendment) Act, 2021.

21. Modifications in the Policy

21.1. Any modification arising out of changes in Guidelines for Wagon Design, IRSOD or any other document referred in this policy may be done with the approval of CWD.

Annexure A- Guidelines for New Wagon Design (GWD)

(45 pages)

GUIDELINES FOR NEW WAGON DESIGN

INDIAN RAILWAYS



GUIDELINES FOR
NEW WAGON DESIGN

S.No.	Month/ Year of issue	Revision/ Amendment	Page No.	Reason for Amendment
1	December, 2021	-	-	First Issue

Issued by

Research Design and Standards Organization Ministry of Railways
Lucknow - 226 011

December, 2021

Vimh

Table of Contents

SCHEDULE – A: Wagon Design 4

1. General..... 4

2. Operating & Service Conditions 4

3. Wagon Design 5

 3.1 General..... 5

 3.2 Standards to be used 5

 3.3 Reliability, Availability, Maintainability and Safety (RAMS)..... 5

 3.4 Key Parameters 6

 3.5 Underframe..... 6

 3.6 Bogie Design..... 6

 3.7 Wheel, Axles & Roller Bearings 6

 3.8 Braking System..... 7

 3.9 Painting and Marking 7

4. Stages of New Wagon Design Approval 7

5. Details of Stages of New Wagon Design Approval..... 8

 5.1 Stage-I: Preparation & Submission of Proposal of New Wagon Design by the Wagon Designer (WD) 8

 5.2 Stage-II: In-principle clearance by Committee on Wagon Design (CWD) 8

 5.3 Stage-III-Detailed Designing of the proposed NWD..... 9

 5.4 Stage-IV-Manufacturing of two Prototype Wagons 12

 5.5 Stage-V- Static and dynamic testing of Prototype Wagon..... 12

 5.6 Stage-VI- Sanction & Manufacturing of two rakes of NWD for field service testing 14

 5.7 Stage-VII- Field Service testing of 2 rakes of NWD: 14

 5.8 Stage-VIII- Final Clearance for unrestricted introduction of NWD on IR 15

Annexure-A: Conditions Applicable to New Wagon Designs Proposed for IR Network..... 16

Annexure-B: Basic Design Parameters of the Proposed NWD To Be Submitted for Concept Design Approval..... 17

Annexure-C: Technical Data of the Proposed NWD 18

Annexure-D: Curve Negotiability 19

Annexure-E: Kinematic Profile..... 20

Annexure-F: Load cases and Boundary Conditions for FEM 21

Annexure-G: Desired Dynamic Performance Characteristics of Wagon..... 22

Vramh

GUIDELINES FOR NEW WAGON DESIGN

Annexure-H: Data Required for Computer Modeling Of Railway Vehicles 23
Annexure -I: List of IRS components..... 32
Annexure-J: Worn wheel profile..... 34
SCHEDULE – B: Stipulation of Boundary Conditions of Track 35
SCHEDULE – C: Stipulation of Boundary Conditions of Bridge 39
SCHEDULE – D: Stipulation of Boundary Conditions of Signalling 44
SCHEDULE – E: Stipulation of Boundary Conditions of OHE..... 45

Vimh

SCHEDULE - A: Wagon Design

1. General

- 1.1 These guidelines are laid down as a part of the "Policy for approval of new Wagon Design" issued by Railway Board.
- 1.2 Evaluation of various types of New Wagon Designs shall be done broadly as per these guidelines by ISA. However, ISA may use his own experience and specify/ask for compliance of additional requirements.
- 1.3 ISA may ask for additional information, over and above, specified in these guidelines, to be provided by WD, which should be promptly furnished.
- 1.4 These guidelines contain the general guiding parameters and boundary conditions for wagon design, manufacturing, inspection, testing, field trial, operation and maintenance. In case of any deviation from these guidelines, the Wagon designer (WD) may approach Committee on Wagon design (CWD). The CWD will examine the issue and accordingly permit deviations, if technically feasible.

2. Operating & Service Conditions

2.

- 2.1 Proposed NWD should have minimum speed potential of 100 kmph in both fully loaded and empty conditions.
- 2.2 Maximum axle load should not exceed 25 t. However, operation at 25 t axle load is permitted only on specific routes of IR and Dedicated Freight Corridors (Western & Eastern).
- 2.3 Environmental conditions:

a)	Altitude	Up to 1800 m from mean sea level
b)	Operating Temperature	-10°C to 50°C During dry weather, the atmosphere is likely to be dusty.
c)	Humidity	Upto 100%
d)	Rainfall	Very heavy in certain areas.
e)	Atmospheric conditions	Extremely dusty and desert terrain in certain areas. The dust concentration in air may reach a high value of 1.6mg/m ³ . In most of iron ore and coal mine areas, the dust concentration is very high
f)	Solar Radiation	1 kW/m ²
g)	Coastal area	Humid and salt laden atmosphere with maximum pH value of 8.5, sulphate of 7 mg per litre, maximum concentration of chlorine 6 mg per litre and maximum conductivity of 130micro Siemens / cm.

Vimh

h)	Wind speed	Wind pressures as per IS 875
----	------------	------------------------------

3. Wagon Design

3.1 General

- 3.1.1 All critical components/assemblies being used in the NWD should be well proven in one of the Railway Systems, which can be having track gauge different from IR (1676 mm). Also, these should be procured from proven/established sources.
- 3.1.2 Compatibility of operation of the wagon by locos currently available on IR, both from the point of view of coupling and application/release of brakes, has to be mandatorily ensured by the WD.
- 3.1.3 Design of other interfacing parts/components of NWD like doors, loading /unloading mechanism should be user friendly and no special skill should generally be required for their operation.
- 3.1.4 WD can use any of the IRS components, as mentioned in Annexure-I, subject to relevant conditions given in the main policy.
- 3.1.5 Calculation of Fatigue life of Wagon and its various components in Kms or in number of years, to be done as per well-established standards.
- 3.1.6 WD should visit some of the areas (loading and unloading points, yards, portion of track, etc.) on which the proposed NWD are intended to be operated & maintained to familiarize himself with the prevailing field conditions, which may be taken into account while designing the wagon.

3.2 Standards to be used

- 3.2.1 Various Standards proposed to be followed for design, manufacturing, inspection, testing, operation and maintenance of NWD should be well established.
- 3.2.2 Standards mentioned in these guidelines are for guidance. WD may use alternative well established standards if it can be demonstrated to ISA that such alternative is at least equivalent or superior or more pertinent to NWD than the standards mentioned in these guidelines.
- 3.2.3 Equivalent IS standards of various standards, if available, shall also be acceptable.

3.3 Reliability, Availability, Maintainability and Safety (RAMS)

- 3.3.1 Reliability, Availability, Maintainability and Safety conforming to EN 50126/IEC 62278 shall be in-built in the NWD.

Vimk

- 3.3.2 Safety Assessment shall be carried out and shall include the following principles:
- 3.3.3 Degraded modes and emergency operations shall be considered as well as normal operations;
- 3.3.4 Safety risk assessment shall utilize more than one methodology to assess risks;
- 3.3.5 Safety risk assessment shall include the consideration of dependent failures, in particular the braking system, bogie suspension, etc.; and
- 3.3.6 Details of RAMS analysis shall be submitted by the WD at the design approval stage to ISA.

3.4 Key Parameters

- 3.4.1 Key Parameters i.e. Axle Load, Track loading density & Main clauses of IR SOD-2004 or latest for compliance of New Wagon Design are provided in Annexure-A.

3.5 Underframe

- 3.5.1 Underframe to be designed as per established standard.
- 3.5.2 Coupler and Draft Gear
- 3.5.3 To be as per established standard.

3.6 Bogie Design

- 3.6.1 The bogie shall be of proven design and shall provide the required riding behavior and comfort.
- 3.6.2 The structural design of the bogie frame to conform to established standard.
- 3.6.3 Testing of the bogie frame shall be done in accordance with established standard.
- 3.6.4 Design of Suspension Elements (Rubber suspension/guiding elements including rubber metal bonded items, Coil Springs, Others) to comply to established standards: -

3.7 Wheel, Axles & Roller Bearings

- 3.7.1 Axles to be designed in accordance with established standard.
- 3.7.2 Wheels to be in accordance with established standard.
- 3.7.3 Wheel sets to be in accordance with established standard.

- 3.7.4 Worn Wheel, wheel profile as per RDSO Drawing no. WD-88201 (attached as Annexure-J) shall be provided on all wheels.
- 3.7.5 Design validation of wheels and axles shall be required to be carried out to validate the design as per relevant international standards.
- 3.7.6 Roller bearings to conform to established standard. Roller bearing selected shall be suitable for the axle load prescribed in this specification. Roller bearing shall be grease lubricated & sealed.

3.8 Braking System

- 3.8.1 Twin pipe graduated release air brake system to be provided
- 3.8.2 Brake system to comply with the UIC leaflet 540 "BRAKES- Air brakes for Freight Trains and Passenger Trains".
- 3.8.3 Brake system shall be designed to provide 100% braking effort.
- 3.8.4 The brake system/rigging can be underframe mounted or bogie mounted
- 3.8.5 Necessary provision for modification in brake rigging while working in empty and loaded condition of cars to be made.
- 3.8.6 Brakes can be either disc type or tread mounted.
- 3.8.7 Adequate safety arrangements to prevent falling off of brake equipments/brake rigging, in the event of failure of any component, on the track should be provided.
- 3.8.8 Emergency Braking Distance (EBD) at a speed of 100 kmph on level track should not be more than 1 km in both dry and wet conditions. EBD Calculations to be done as per UIC 544-1.
- 3.8.9 Air reservoirs - should be compliant to established standard.
- 3.8.10 Parking Brake (Hand brake)- shall be designed to hold NWD on the gradient of 1 in 37 for unlimited time.

3.9 Painting and Marking

- 3.9.1 PU/Equivalent or superior paint to be used, so as to protect the NWD from corrosion and other weathering effects.
- 3.9.2 Suitable pictograms explaining the working of interfacing components used in operation & important precautions to be provided at suitable locations.

4. Stages of New Wagon Design Approval

Vinik

Various stages involved in approval of New Wagon Design by WD are as under:

Stage-I	Preparation & Submission of Proposal of New Wagon Design (NWD) by the Wagon Designer (WD)
Stage-II	In-principle clearance by the Committee on Wagon Design (CWD)
Stage-III	Detailed Designing of the proposed NWD
Stage-IV	Manufacturing of two Prototype Wagons
Stage-V	Static and Dynamic testing of Prototype Wagons
Stage-VI	Sanction & Manufacturing of two rakes of NWD for field service testing
Stage-VII	Field Service testing of 2 rakes of NWD2.
Stage-VIII	Final Clearance for unrestricted introduction of NWD on IR

5. Details of Stages of New Wagon Design Approval

Details of stages of NWD approval:

5.1 Stage-I: Preparation & Submission of Proposal of New Wagon Design by the Wagon Designer (WD)

Detail procedure for preparation and submission is given in para no- 4.1 of the Policy issued by Railway Board.

5.2 Stage-II: In-principle clearance by Committee on Wagon Design (CWD)

Following information/documents shall be submitted by Wagon Designer (WD) to the Committee on Wagon Design (CWD) for In-principle clearance of the NWD:

5.2.1 Basic design parameters as per Annexure 'B'

- a) General arrangement diagram
- b) Overall proposed NWD diagram duly superimposed on MMD Diagram 1D as per IRSOD Revised 2004 with latest amendment for checking of infringement & necessary clearances.
- c) Type of NWD: General Purpose, Commodity Specific, Route Specific
- d) Type of Commodity(ies) proposed to be carried and load distribution thereof

- e) Suitability of loading/unloading methods and equipments for the existing facilities on IR system
- f) Type of Material proposed to be used in NWD
- g) List of IRS components proposed to be used, if any, in NWD
- h) List of own design/ third party design components proposed to be used in the NWD
- i) Various Standards proposed to be followed for design, manufacturing, inspection, testing, operation and maintenance of NWD

5.3 Stage-III-Detailed Designing of the proposed NWD

5.3.1 Wagon designer (WD) shall approach the selected ISA and submit the concept design submitted to CWD for his scrutiny and comments and accordingly proceed with the detail wagon design.

5.3.2 Following Information relating to the Wagon body & assemblies shall be provided by WD to ISA:

5.3.2.1. General

- a) Design considerations like factor of safety, dynamic augment, fatigue allowance criteria (general or component specific)
- b) Precautions which should be taken for the complete cycle from loading to unloading to take care of the working conditions/problems in the proposed design.
- c) Various Standards followed for design, manufacturing, inspection, testing, operation and maintenance of NWD with a copy of respective standard

5.3.2.2. Wagon body

- a) Product structure plan, which shows how the key elements such as components, sub- assemblies & assemblies form the final product.
- b) Design drawings of key elements which show the main principle of design accompanied by a short description & as far as necessary for understanding of the design.
- c) Criteria for the selection of materials & methods for their evaluation. (If such materials are in use in other existing wagons, it should be mentioned.)
- d) Details of various structural joints.

Vimh

- e) Conformance of the underframe to the standard mentioned in clause 2.6 & 2.7

5.3.2.3. Bogie, including its components e.g. wheel, axle, bearing, etc.

- a) Details of running of same design of bogie in one of the Railway Systems and performance thereof
- b) Details of bogies and its various Diagram of bogie showing various components and their linkages
- c) Conformance of the bogie and its various components to the standards mentioned in clause 2.6 & 2.7

5.3.2.4. Brake system

- a) Air brake system overview, components and operation
- b) Brake schematic diagram
- c) Brake rigging diagram
- d) Brake power diagram
- e) Braking effort calculations
- f) EBD Calculation for both dry and wet conditions
- g) Parking Brake (Hand brake) arrangement and grade calculations
- h) Number, dimension and type of brake blocks
- i) Test Plan comprising of Test Matrix, Test Schedules and Test Procedures
- j) Conformance to the standards mentioned in clause 2.8

5.3.2.5. Coupler & Draft gear

- a) Type of Coupler and draft gear proposed to be used in NWD
- b) Details of running of same design of coupler and draft gear in one of the Railway Systems and performance thereof

5.3.2.6. Loading and unloading systems

- a) Requirement of any special loading/unloading systems in the wagon/in the field for each type of commodity to be carried. If yes, details of fitment/installation and operation of such systems

- b) Details of Manufacturer of such loading and unloading systems
- c) Details of securing/lashing system, as applicable, and its adequacy for the each commodity proposed to be carried

5.3.2.7. Information about design methods and calculations (not applicable for IRS components/design):

- a) Standards used for design and calculation
- b) Computer programs used for design & calculation
- c) Results of FEM analysis for the wagon body for different load conditions. Load conditions are given in **Annexure-‘F’**.
- d) Details of computer program used for FEM analysis, boundary conditions, load conditions, etc. considered in the FEM analysis.
- e) Fatigue Analysis of wagon structure. Load environment data given in Chapter-VII of AAR, Section Part-II to be used for fatigue analysis.
- f) Results of vehicle dynamic analysis & input data (Track Input file for carrying out vehicle dynamic analysis to be provided by RDSO). The present dynamic performance characteristics as laid down by the Criteria Committee are given in **Annexure ‘G’**. These dynamic performance characteristics may be revised by RDSO in future.
- g) Input data along with their basis and supported calculation for vehicle dynamic analysis shall be submitted by WD if so desired by RDSO as per **Annexure ‘H’**.

5.3.2.8. Technical data:

- a) Technical data of wagon regarding C.G., Weight distribution, curve negotiability, Kinematic Profile, throw over at head stock, etc. to be submitted as per the enclosed **Annexure ‘C’**. Conditions for curve negotiability are given in **Annexure-‘D’**. Condition for Kinematic Profile are given in **Annexure-‘E’**

5.3.2.9. Painting & Marking

- a) Painting scheme & Marking diagram

5.3.2.10. Quality Assurance Plan (QAP)

Vimh

- a) A detailed Quality Assurance Plan (QAP) for stage inspection and final inspection of prototype wagons
- b) Should include: parameters to be checked, acceptance values, methodology to be used for checking, reference standards, frequency of inspection by WD and ISA, etc.
- c) QAP shall be got approved from ISA

5.3.2.11. Information about maintenance and examination of proposed Wagon Design

- a) Proposed maintenance regime of the NWD and various standards proposed to be followed
- b) Details of various Maintenance Schedules, standards to be followed, activities to be carried out, dimensions to be checked, permissible limits of wear, etc. for yard examination and other major maintenance schedules.
- c) Inspection procedure and periodicity of various inspection schedules in detail including the gauging practices to be followed for yard examination and other major maintenance schedules.
- d) Maintenance procedures in detail
- e) Machinery and equipment required for maintenance
- f) Gauges, jigs & fixtures required for maintenance
- g) Space requirement for maintenance activity

5.4 Stage-IV-Manufacturing of two Prototype Wagons

- 5.4.1 All the fabrication & the workmanship shall meet the requirements of standard(s) proposed to be followed by WD.
- 5.4.2 The surface preparation and painting shall be as per painting scheme developed by WD based on standard proposed to be used.
- 5.4.3 Stage and final Inspection of the NWD during its manufacturing shall be conducted by ISA, as per approved QAP.

5.5 Stage-V- Static and dynamic testing of Prototype Wagon

- 5.5.1 Static Test Scheme for the NWD shall conform to the standard proposed to be used. It should include:
 - 5.5.1.1. Complete test schedule for wagon & components

Vimh

- 5.5.1.2. The test schedule should reflect material, components, sub - assemblies, assemblies & the finished product and will distinguish between:
 - a) Type acceptance tests, Production Tests & Quality Check Tests
 - b) Test on first article or on further wagons with test sequence
 - c) Location of test site i.e. contractor's works, etc.
 - 5.5.1.3. Tests description, procedures and documentation of tests
 - 5.5.1.4. Details of Test equipment's required
 - 5.5.1.5. Format of recording various test results
-
- 5.5.2 For facilitating static testing, the WD shall provide:
 - 5.5.2.1. Assembly drawings for sub-assemblies, assemblies and the final product. These will be accompanied by quality requirements, test and inspection requirements
 - 5.5.2.2. Information about quality Control which includes Quality Assurance Plan & Welding Procedure System/joints preparation details.
 - 5.5.3 The WD shall make the prototype wagon available at the nominated place for conducting static test by ISA.
 - 5.5.4 The Following tests may be referred for guidance:
 - 5.5.4.1. Dimensional and welding check as per check sheets developed by ISA.
 - 5.5.4.2. Brake force test as per proposed standard.
 - 5.5.4.3. Load test in empty, loaded, over loaded, overloaded in 18 hrs at tangent and at 10 degree curve.
 - 5.5.4.4. Squeeze load test by applying compressive load at the end on wagon.
 - 5.5.4.5. Shower test for checking leakage/ water in body, as applicable, and grease.
 - 5.5.4.6. Hydraulic test of tank Barrel as per guidelines of Chief Controller of Explosives, as applicable
 - 5.5.4.7. Tank calibration test as per the guidelines of Tank calibration committee, , as applicable
 - 5.5.4.8. Discharge test as per proposed standard
 - 5.5.4.9. Door operating mechanism functional test as per any proposed standard
 - 5.5.5 Dynamic testing shall be carried out by ISA as mentioned in Annexure-G.

Vinsh

5.6 Stage-VI- Sanction & Manufacturing of two rakes of NWD for field service testing

Details are provided in the Railway Board guidelines

5.7 Stage-VII- Field Service testing of 2 rakes of NWD:

- 5.7.1 Two (2) rakes duly inspected by ISA will be inducted for test and trials (at least one full rake to be introduced at a time).
- 5.7.2 Special trials like Emergency braking distance/Coupler force/ controllability shall be undertaken by ISA, on one rake of NWD, on nominated section of IR track.
- 5.7.3 Field service testing shall be carried out for 50,000 km for each rake.
- 5.7.4 WD shall prepare detailed check-sheet covering all the main parameters and the acceptance criteria for the key parts/components. The check-sheet should be approved by ISA before commencement of the field trials
- 5.7.5 Performance of following key components shall be mandatorily assessed in the field trial:

S.No.	Name of part
01	Bogie complete (including side bearer, suspension, EM pads, bolster and side frame castings And C.P. TOP)
02	Wheel set including Bearing
03	Brake system (Brake cylinder, DV, Reservoir, empty load devices, Brake shoe etc.)
04	Brake rigging (Brake leverage, loaded & empty tie rod, slack adjuster, control rod, pull rod etc.)
05	Hand brake
06	Coupler
07	Draft gear
08	Lashing and securing arrangements
09	Doors
10	Underframe members
11	Body/super structure
12	Welding/fastening
13	General conditions i.e. abnormal wear, corrosion, sagging, abrasion, crack and breakages etc.

Vimh

5.8 Stage-VIII- Final Clearance for unrestricted introduction of NWD on IR

- 5.8.1 After scrutiny of field trial reports, committee on wagon design (CWD) will issue final clearance for unrestricted introduction of the new wagon design on IR

Vink

Annexure-A: Conditions Applicable to New Wagon Designs Proposed for IR Network

I. Up to 22.9t axle load -

(i) Track Loading Density: 8.355* t/m (maximum)

**For details please see Schedule-B & Schedule-C*

II. More than 22.9t axle load and upto 25 t axle load -

(i) Track Loading Density: 9.33 t/m** (maximum)

***For details please see Schedule-B & Schedule-C*

III. Proposed design shall conform to requirements of IR SOD-2004 or latest, issued by Railway Board [Key parameters as given in Chapter IV(A) are mentioned below]:

S.no	Clause No	Parameter	value
01	02	Wheel Diameter New (Max./Min)	1092/914 mm
02	09,11	Floor height (Max./Min)	1345/1145 mm
03	13 & 14	Coupler Height (Max./Min)	1105/1030 mm
04	16 & 17	Bogie Centre Distance (Max./Min)	14900/5400 mm
05	18(i)	Wheel Base of Bogie (Min.)	1830 mm
06	19(b) & Note	Length of body or Roof (Max./Conditional)	21340/23540 mm
07	20(b) & Note	Length over couplers (Max./Conditional)	22300/24000 mm
08	21	Max. distance apart between any two adjacent axles	12345 mm
		Minimum clearance of all items except wheel from rail level with fully worn wheels	91mm
		Minimum clearance for the body mounted under slung equipment under loaded condition with fully worn wheels	215 mm
		Maximum Moving Dimension (1d-2004)	
09	22	Maximum width at 102 mm above R.L.	2440 mm
10	23	Maximum width at 305 mm above R.L.	3050 mm
11	24	Maximum width from 305 mm to 1082 mm	3050 mm
12	25	Maximum width from 1082 mm to 1170 mm	3250 mm
13	26	Maximum width from 1170 mm to 3735 mm	3250 mm
14	29	Maximum height above rail level for a width of 760mm on either side of the centre of unloaded vehicles	4265 mm

Vimh

Annexure-B: Basic Design Parameters of the Proposed NWD To Be Submitted for Concept Design Approval

PARAMETER	DETAILS
A. General	
1. Axle Load (in tonnes)	
2. TLD (in tonnes/meter)	
3. Tare weight of complete wagon (in tonnes)	
4. Payload of a wagon (in tonnes)	
5. Payload to Tare Weight ratio	
6. Numbers of wagon in 636 meter length	
7. Payload of rake in 636 meter length (in tonnes)	
8. Height of C.G. in loaded condition for lightest commodity proposed to be loaded (in millimeters)	
9. Height of C.G. in empty condition (in millimeters)	
10. Commodity for which wagon is designed	
11. Other commodities, which may be carried in the wagon	
B. Overall Dimensions (in millimeters)	
1. Length over coupler faces	
2. Inside Length	
3. Length between bogie centers	
4. Length over head stock	
5. Coupler height over level Track from rail level	
6. Overall width	
7. Inside width	
8. Floor height from rail level	
9. Inside height	
10. Wheel Base	
11. Volumetric Capacity (in cubic meter)	
12. Volumetric Capacity of heap Loading(in cubic meter)	
13. Total Volumetric Capacity (in cubic meter)	

Note: Maximum center of gravity in the IR system is not defined. However, wagons with a maximum center of gravity of 3139mm are running in the system i.e. double stack container operation.

Vimk

Annexure-C: Technical Data of the Proposed NWD

Following technical data of proposed wagon design shall be submitted:-

- a. Weight distribution indicating lateral & longitudinal unbalance (weight calculation shall be done according to the standard EN 15663 or equivalent)
- b. Balancing calculation for the wagon
- c. Method of adjustment of wheel /axle load
- d. Calculation of unsprung mass
- e. Vogel's layout for 10 degree curve and for 1 in 8.5 turnout for bogie negotiability
- f. Throw-over at head-stock/wagon and coupler movements together with details of clearance.
- g. Estimation of flange forces on curves and turnouts
- h. Stress analysis of all major stress bearing parts of the under frame under static & dynamic conditions
- i. Calculation for energy absorption
- j. Projected dynamic augment with the unsprung masses as used with the IR track
- k. Stability calculation
- l. Vibration analysis of the wagon body and the natural frequencies.

Vinuk

Annexure-D: Curve Negotiability

1. Curve negotiability shall be verified in following conditions:
 - (i) On curves having a radius of 175m
 - (ii) 8:1/2 turnout
 2. Following documents may be referred for calculating curve negotiability:
 - (i) AAR-M-1001
 - (ii) UIC-505
 3. WD may also select some other equivalent standard for calculating the curve negotiability.
-

Vimle

Annexure-E: Kinematic Profile

1. The Kinematic Profile of proposed NWD shall be developed for Indian Railways infrastructure condition as per IRSOD in following conditions:
 - a) Tangent Track
 - b) Curve Track (175m radius)

2. Following may be considered for developing the Kinematic Profile.
 - (i) Lateral movement of wagon due to various clearances between wagon parts.
 - (ii) Tilting of wagon due to suspension deflection.
 - (iii) Track effects-
 - a) Rail wear (Vertical and Lateral) ;
 - b) Lateral track movement - (separately for straight track and for curved track) ;
 - c) Cant on curves;
 - d) Track tolerances;
 - e) Horizontal curvature effects;
 - f) End throw;
 - g) Middle throw; and
 - h) Any other effect of track influencing kinematic profile.

3. Following documents may be referred for developing the Kinematic Profile:
 - (i) AAR-M-1001
 - (ii) UIC-505

4. WD may also select some other international standard for calculating the curve negotiability.

Vimk

Annexure-F: Load cases and Boundary Conditions for FEM

Load Cases	Description	Value	Acceptable Criteria
Load Case - 1	Buff load (Horizontal compressive force at Back stop location on both ends of wagon)+ Gravity load	Buff load= 'x' t Gravity =weight of the structure	Shall be decided by ISA
Load Case - 2	Buff load + Gravity load + Pay load	Pay load= 'y' t	
Load Case - 3	Buff load + Gravity load + Pay load (with dynamic augment of 40%) + lateral force (horizontal force due to payload with 40% dynamic augment) on side wall and end wall.	Buff load= 'x' t Pay load= 'y'*1.4 Lateral force= 'z' t (on each side wall) Lateral force on end wall	
Load Case - 4	Draft load (Horizontal tensile force at striker casting location on both ends of wagon) + Gravity load	Draft load= 'x/2' t Gravity =weight of the structure	
Load Case - 5	Draft load + Gravity load + Pay load (vertical uniform loading on floor area)	Pay load= 'y' t	
Load Case - 6	Draft load Gravity load + Pay load (with dynamic augment of 40%) + lateral force (horizontal force due to payload with 40% dynamic augment) on side wall and end wall	Draft load= 'x/2' t Pay load= 'y'*1.4 Lateral force= 'z' t (on each side wall) Lateral force on end wall	
Load Case - 7	Compressive load on side walls due to tippler	Side wall load =Due to tippler	
Load Case - 8	Coupler Jacking load		
Load case - 9	Roof load		
Load case-10	Floor load due to Fork lift/ Truck wheel load		

Note:

1. Presently IR is taking value of 'x' as 300t for 22.9t axle load wagons.
2. WD of ISA may also select some other international standard/ criteria for FEA analysis.

Vinod

Annexure-G: Desired Dynamic Performance Characteristics of Wagon

Simulated performance of the proposed wagon design shall satisfy the prevailing acceptance criteria at a speed of 110 kmph. Only those proposals whose performance values have been found within acceptable limits, as per the current report of 'The Standing Criteria Committee for evolving criteria for assessment of stability of Rolling Stock on Indian Railways', will be considered for further evaluation.

Indian Railway is in process of switching over to testing criteria from "3rd Criteria committee's Report of RDSO" to "EN14363 standards". Hence, the trial may be conducted from either existing criteria or as per "EN14363 standards". However, final decision in this regard shall be taken by IR. NWD shall be capable of successfully undergoing testing as per both the criteria.



Annexure-H: Data Required for Computer Modeling Of Railway Vehicles

(Values of parameters are to be defined in units as indicated against the respective parameters. Unless otherwise specified, the units are Mega-gram for Mass and Mega-gram-meter- square for inertia, mm for length, radian for angle. Principle axes pass through the CG of the heavy body. Coordinate system for the required data as specified below is given in Annexure-1 and method of specifying the body CG heights and suspension mid-point and heights are given in Annexure -2). The list given below is not exhaustive and if the bidders have used any data in addition to the list given below, same should be furnished.

1. Masses, Inertia and CG Heights

Masses and moment of inertia (I) of the car body, bolster, side frames and wheel/axle set about three principal axes passing through respective CGs as per following format.

1.1 Car body

	Tare Load Condition	Gross Load Condition
Mass* (In Metric tonne)		
Moment of Inertia IXX in Roll (in Mg-m ²)		
Moment of Inertia IYY in Pitch (in Mg-m ²)		
Moment of Inertia IZZ in Yaw(in Mg-m ²)		

*Mass of car body = Tare Weight of wagon - 2 X (Weight of Bogies).

1.2 Bolster:

Parameter	Value
Mass* (In Metric tonne)	
Moment of Inertia I _{xx} in Roll (in Mg-m ²)	
Moment of Inertia I _{yy} in Pitch (in Mg-m ²)	
Moment of Inertia I _{zz} in Yaw (in Mg-m ²)	

1.3 Side Frame:

Parameter	Value
Mass* (In Metric tonne)	
Moment of Inertia I _{xx} in Roll (in Mg-m ²)	
Moment of Inertia I _{yy} in Pitch (in Mg-m ²)	
Moment of Inertia I _{zz} in Yaw (in Mg-m ²)	

**Mass = 1/12 Wt. Of bogie - (bolster Wt. + 2X Wt. Of wheel set with axle Boxes + Wt. Of 2 radial arms)

Vink

1.4 Wheel Set:

Parameter	Value
Mass* (In Metric tonne)	
Moment of Inertia I_{xx} in Roll (in $Mg \cdot m^2$)	
Moment of Inertia I_{yy} in Pitch (in $Mg \cdot m^2$)	
Moment of Inertia I_{zz} in Yaw (in $Mg \cdot m^2$)	

Mass = Weight of {wheel and axle + two axle boxes + radial arm}

2. Center Pivot:

Parameter	Value
Type of pivot (Flat or Spherical)	
Diameter of pivot	
Radius of curvature (if spherical)	
Radial clearance (if flat)	

3. Side Bearer:

3.1	Parameter		Value
3.2	Lateral distance between side bearer centers on the same bolster	=	
3.3	Number of springs in each side bearer nest	=	
3.4	Pre-compression (displacement) of side bearer springs under tare	=	
3.5	Clearances (if any) of:		
3.5.1	Longitudinal/Lateral stoppers	=	
3.5.2	Vertical stoppers	=	

4. Space coordinates and connections

4.1 Space coordinates of CGs of all heavy bodies viz. Car body, bolster, side frames, wheel/ axle set with respect to mid-point of lead axle at rail level under tare conditions under Body CGs: Location in tare, loaded and fully unloaded (released state of suspension) condition to be indicated as per following format.

(Please refer to Annexure - I and II for explanation)

Heavy Body	X	Y	Z		
			Z1	Z2	Z3
			Under Fully un-loaded condition (all springs released)	Under Tare load condition	Under Gross load condition

Vim

GUIDELINES FOR NEW WAGON DESIGN

Main Car body					
Leading Bolster					
Trailing Bolster					
Leading side-frame left					
Leading side-frame right					
Trailing side-frame left					
Trailing side-frame right					
Leading bogie leading axle					
Leading bogie trailing axle					

- 4.2 Space coordinate of mid point of all connections between car body and bolster, bolster and side-frame, side frame and axle including primary and secondary suspensions, with respect to mid point of lead axle at rail level may please be tabulated for each connection under tare and fully loaded conditions.

(Please refer to Annexure - 1 and 2 for explanation)

Important: Separate tables must be filled up and furnished for free condition, tare condition and gross load condition for relevant parameters

4.2.1	Height of center pivot from rail level	=	mm
4.2.2	Center pivot diameter	=	mm
4.2.3	Height of side bearer vertical connection	=	mm
4.2.4	Lateral distance between two secondary spring nests	=	mm
4.2.5	Vertical height of each secondary nest from rail level	=	mm
4.2.6	Height of elastomeric pad from rail level	=	mm
4.2.7	Height of spring plank (if present) from rail level	=	mm
4.2.8	Lateral distance of wheel/rail contact point	=	mm
4.2.9	Side bearer vertical stiffness per side bearer connection	=	MN/m

4.3 Connection Characteristics

- 4.3.1 Stiffness and damping characteristics of side-bearer between car body and bolster in vertical, lateral and longitudinal mode, for each nest may please be specified as under:

I.	Vertical stiffness and damping characteristics of the secondary spring group as a hysteresis loop.	
II	Vertical stiffness of spring nest / side bearer	_____MN/m

Vimk

III.	Vertical damping at side bearer level	_____MN
IV.	Lateral stiffness of spring nest / side bearer	_____MN/m
V.	Lateral damping at side bearer level	_____MN
VI.	Side bearer yaw connection series type stiffness per bogie	_____MN-m/radia
VII.	Yaw damping at side bearer per bogie	_____MN-m
VIII.	Hysteresis loop of the primary suspension in vertical mode (if elastomeric pads are proposed)	Extension and compression loops
IX.	Stiffness characteristics of the primary suspension in lateral mode	
X.	Damping characteristics of the primary suspension in lateral mode	
XI.	Stiffness characteristics of the primary suspension in longitudinal mode	
XII.	Damping characteristics of the primary suspension in longitudinal mode	

4.3.2 Center Pivot characteristics

Yaw damping characteristics at center pivot (between car body and bolster).

- i. Under tare condition= MN-m
- ii. Under loaded condition = MN-m

4.3.3 Primary Suspension details

	In Tare	In Loaded	Unit
Vertical stiffness of primary suspension at each axle box			MN/m
Lateral stiffness of primary suspension at each axle box			MN/m
Longitudinal stiffness of primary suspension at each axle box			MN/m
Vertical damping of primary suspension at each axle box			MN
Lateral damping of primary suspension at each axle box			MN
Longitudinal damping of primary suspension at each axle box			MN

Vimh

Hysteresis loops in vertical, lateral and longitudinal modes may be provided for elastomeric pads. If the same has been modeled as a parallel pair, then force - deflection characteristics may be provided.

4.4 Secondary Suspension

- i. Secondary vertical springs hysteresis loop per group may be given.
- ii. Additionally Hysteresis loop for load proportional damping should be specified.

	Tare	Loaded	Unit
Secondary vertical stiffness per group			MN/m
Secondary lateral stiffness per group			MN/m
Secondary longitudinal stiffness/group			MN/m
Secondary vertical damping/group			MN
Secondary lateral damping/ group			MN
Secondary longitudinal damping/ group			MN

4.5 Relative pitch and relative yaw characteristics (stiffness and damping) between the two side frames. If spring plank is additionally provided between the two side frames, then these characteristics should be provided for configuration with plank and without plank separately.

I.	Relative pitch stiffness	=	MN/m/bogie
II.	Relative pitch damping	=	MN
III.	Relative longitudinal stiffness	=	MN/m/bogie
IV.	Relative longitudinal damping	=	MN

- 4.6 a) Non-linear connection characteristics should be specified in the form of force-displacement/force-velocity graphs and additionally, Piecewise linear characteristics graphs in terms of load and deflection should be provided.
- b) When defining connections between two heavy bodies, the type of connection viz. series pair, parallel pair of spring and damper or a hysteresis should be clearly specified.
- c) Wheel rail contact geometry should be given in full details and with the full wheel-rail contact geometry table.

4.7 Degree of freedom of connection between two heavy bodies should be indicated as under:

Vimk

	Heavy Body	Define each connection, its type (series pair/parallel pair/hysteresis, etc.) its degrees of freedom modeled
a.	Car body - bolster	
b.	Bolster - side-frame	
c.	Side-frame - axle	
d.	Wheel-set - rail	
e.	Side frame to side frame	

Location of mid-point of connection in tare and loaded condition must be indicated separately for tare condition and gross loaded condition.

(Please refer to Annexure - 1 and 2 for explanation)

5. Design Particulars:

5.1	Wheel diameter	=	mm
5.2	Wheel base	=	mm
5.3	Bogie center distance	=	mm
5.4	Tare weight of wagon	=	mm
5.5	Static deflection of car body CG Under tare load	=	mm
5.6	Static deflection of car body CG Under gross load	=	mm
5.7	Height of car body CG from rail level under fully released condition of primary and secondary vertical springs and side bearer.	=	mm
5.8	Height of CG of car body from rail level under tare condition.	=	mm
5.9	Height of CG of the car body of the fully loaded vehicle from rail level	=	mm

6. Clearances:

6.1	Lateral Gib clearance at axle box between side frame and axle boxes	=	+	mm
6.2	Longitudinal Gib clearance at axle box between side frame and axle boxes	=	+	mm

Vinuk

6.3	Lateral Gib clearance between bolster and side frame at secondary stage	=	+	mm
6.4	Lateral clearance between body and bolster at center pivot for flat pivot	=	+	mm
6.5	Any other clearances at bump/rebound stops provided as part of the suspension (please elaborate).	=	+	mm

7. Spring design details:

Spring details of all the springs used at various levels viz. Primary, secondary springs (inner, outer, snubber) side bearer springs etc. with following particulars: -
(Separate table may please be made for each spring)

7.1	Free height	=	mm
7.2	Home height	=	mm
7.3	Mean coil diameter	=	mm
7.4	Pitch circle diameter	=	mm
7.5	Number of turns (effective)	=	_____
7.6	Wire diameter	=	mm
7.7	Stiffness	=	Kg/mm

8. If the bogie has radial steering mechanism, following data may be furnished.

- (i) Inter-axial shear stiffness= _____MN/m
- (ii) Inter-axial bending stiffness = _____MN/m/Radian

Details of the calculations of the above two values may also please be provided.

9. Drawing & Sketches:

- 9.1 Detailed design drawings of Bogie may please be furnished.
- 9.2 Drawing of the side bearer with housing may please be furnished.
- 9.3 Co-efficient of friction may please be specified at:
 - a) Side bearer
 - b) Center Pivot
 - c) Wedge block at secondary suspension
- 9.4 A paragraph bringing out the salient features of the suspension should be provided along with sketch/drawing of suspension arrangement.

Vinik

- 9.5 Data in any system / unit of measurement other than the mentioned are not acceptable.

Vimk

Annexure -1
Coordinate system for specifying the vehicle's geometry to create the mathematical model for doing its theoretical assessment

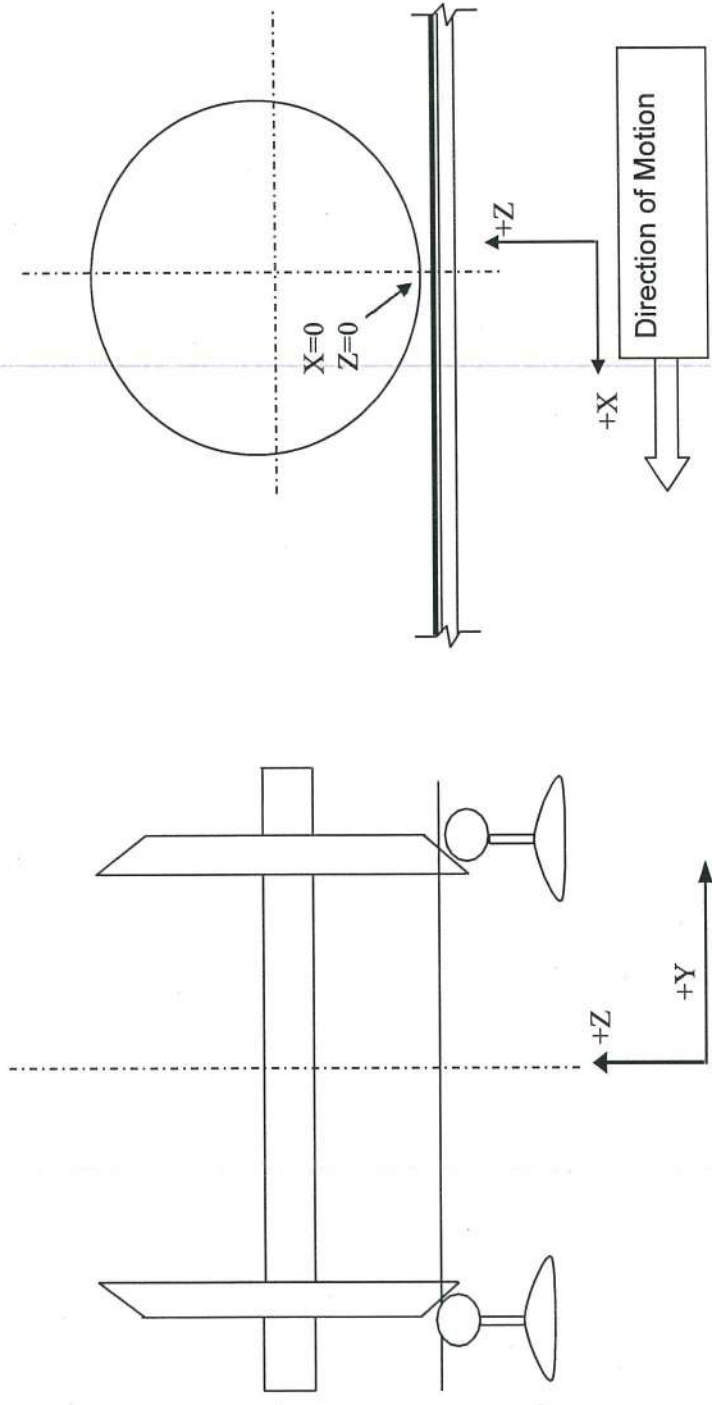

Vimk

Specifying Center of Gravity height for two stage suspension

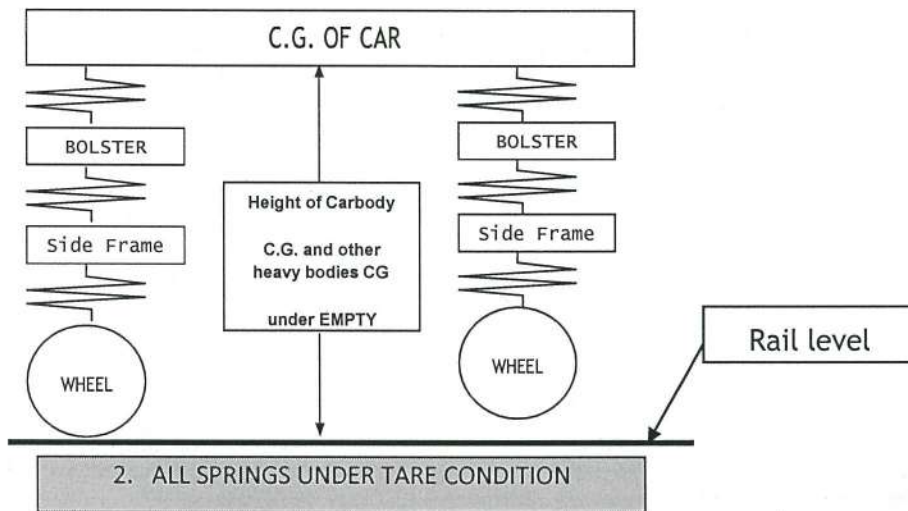
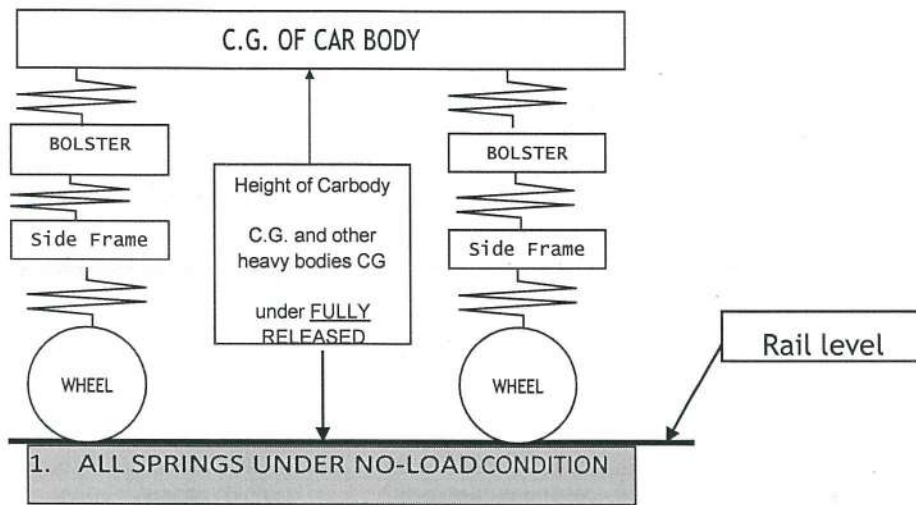

Annexure-I:

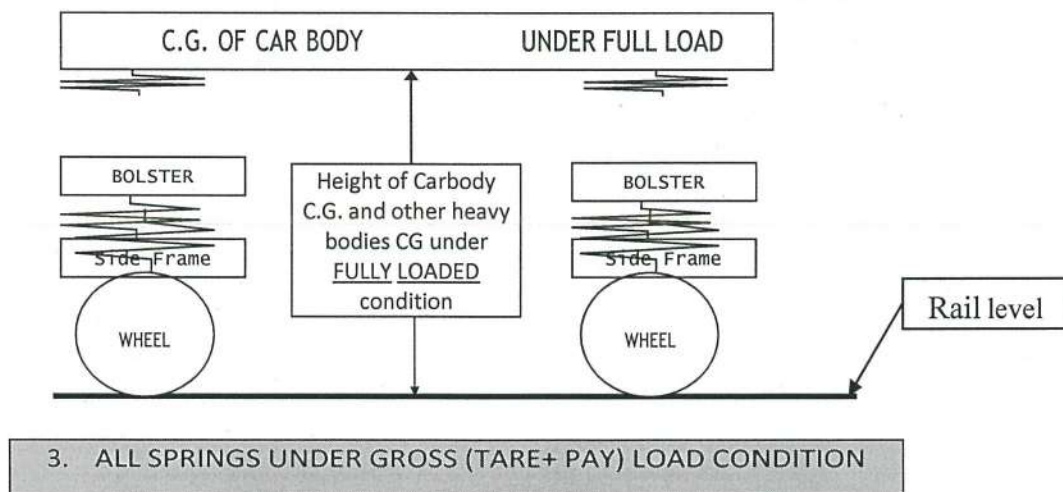

Vinuk

Annexure – I: List of IRS components

S. No.	Component name	Variant	Specification
1	Bogie	CASNUBHS	WD-17-CASNUB-22HS- BOGIE-92
		CASNUB NLB	WD-21-CASNUB-22NLB-BOGIE-93
		LCCF	CONTR-LCCF20(C)-96
		LWLH	WD-14-LWLH-25 BOGIE/K- CLASS-2015
2	Brake system	Bogie Mounted Brake System	WD-23-BMBS- 2008
		Graduated Release Air Brake System	02-ABR-02
3	Coupler	Upgraded High Tensile CBC	WD-70-BD-10
		Slackless Draw Bar	WD-73-BD (SDB)-20
	Draft Gear	High Capacity Draft Gear	WD-49- BD-08
		Upgraded High Capacity Draft Gear	WD-71- BD-15
5	Wheel Set	1000 mm dia wheel with axle	IRS-R-19/93 (Part-1)
		840 mm dia wheel with axle	IRS-R-19/93 (Part-1)
6	Bearing	Class E CTRB	AB/RB-39-2002
		Upgraded Class E CTRB	AB/RB-40-2016
		Class K CTRB	AB/RB-41-2016
7	Brake Block	L type	13-ABR-2019
		K type	14-ABR-2019

Annexure-J: Worn wheel profile

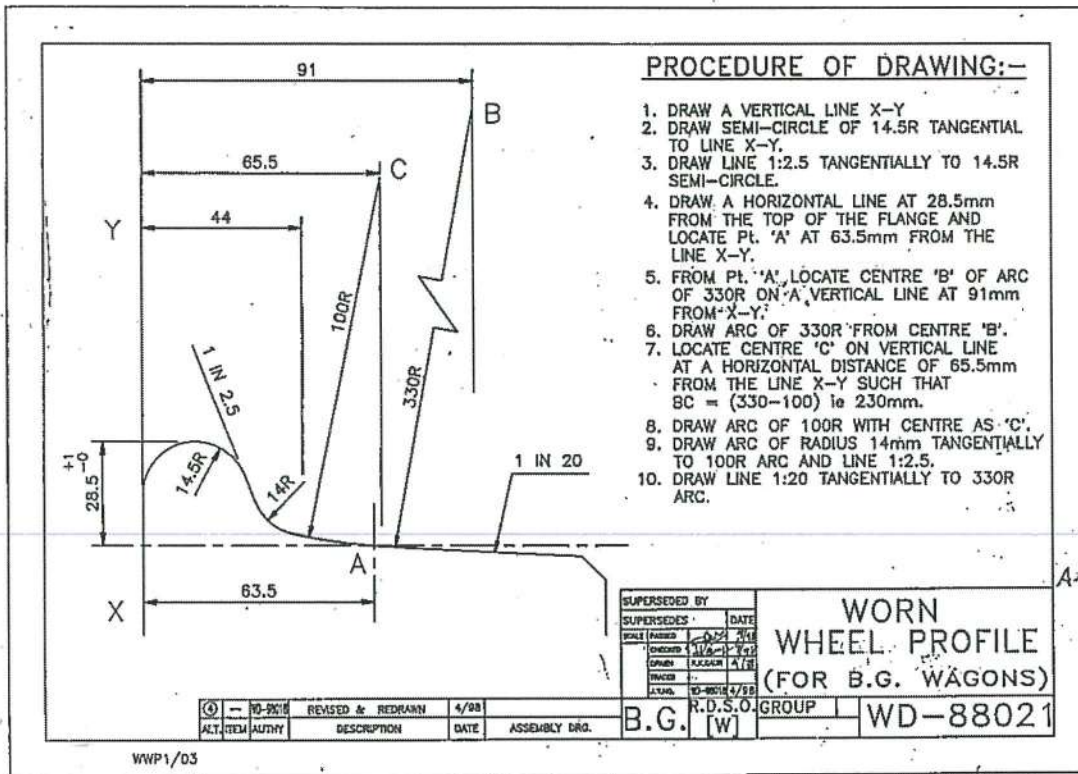

Vimk

SCHEDULE - B: Stipulation of Boundary Conditions of Track

Track Parameters:

1.	Gauge	Indian Railways Schedule of Dimensions for Broad Gauge (1676mm) Revised, 2004 (with latest amendments)	
2.	Sharpest curve to be negotiated	Horizontal-175 m radius Vertical - 2500 m for group C, D and E routes	
3.	Sharpest turnout to be negotiated	1 in 8½ turnouts on pre-stressed concrete sleepers for 60 kg (UIC) or 52 kg rail	
4.	Permissible speed at turn outs	1 in 8½ curved switch 52/60 kg on Pre-Stressed Concrete (PSC) sleepers – 15 kmph	
		1 in 8½ symmetrical split with curved switches 52/60 kg on PSC sleepers- 30 Kmph	
		1 in 12 curved switch 52/60 kg on PSC sleepers- 30 Kmph	
5.	Maximum Super elevation	140 mm for group D and E routes	
6.	Maximum Cant deficiency	For speed > 100 kmph	: 100 mm
		For speed upto 100 kmph	: 75 mm
		As per Para 404 (2) of IRPWM, June-2020.	
7.	Maximum Gradient	1:37	
8.	Permissible Track Tolerances	As given in Para 522 of Indian Railway Permanent Way Manual (IRPWM) June-2020.	
9.	Gauge (Under floating Condition)	As mentioned in Para 525 of Indian Railway Permanent Way Manual (IRPWM) June-2020.	
		Straight Track	-6mm to +6mm
		Curved Track with more than 440 m radius	-6mm to +15mm
		Curved Track with less than 440m radius	Upto +20mm

Track Classification:

The Broad Gauge (BG) lines on Indian Railways, as per **Indian Railways Permanent Way Manual (IRPWM)**, have been classified into six groups, 'A' to 'E' on the basis of the future maximum permissible speed as under:

Vimb

i.	Group 'A'	Speeds up to 160 kmph
ii.	Group 'B'	Speeds up to 130 kmph
iii.	Group 'C'	Sub-urban Sections of Mumbai, Delhi, Chennai and Kolkata
iv.	Group 'D' Spl.-	Speeds upto 110 kmph & annual traffic density is 20 GMT or more.
v.	Group 'D'	Speeds upto 110 kmph & annual traffic density is less than 20 GMT.
vi.	Group 'E'	All other Sections and branch lines with speed upto 100 kmph.

(C) On IR, there are following four speed bands. The train speed limit is regulated in accordance with track structure and maintenance standards in respective speed bands:

1. Upto 100kmph
2. From 100 kmph to 110 kmph
3. From 110 kmph to 130 kmph
4. From 130 kmph to 160 kmph

(D) The maximum permissible speed is based on Rail stress calculation methodology and parameters considered in RDSO report of 25t axle load of 2018. (References for rail stress calculation methodology are Technical paper-323, 245, Technical Monogram TM-12, Track Stress Research progress report volume 1 by Gelson and Blackwood).

For New wheel diameter of 914-1092 mm, the minimum boundary parameters in accordance with wheel base of 2.0m and Bogie Centre distance as per IRSOD, revised 2004 for given maximum permissible speed and for different axle loads may be as follows:

(a) 20.32t axle load:

Type of Rail	Dynamic Augment	Wheel Diameter (New)	Max Permissible Speed (Kmph)
52kg 90UTS	≤ 53.5%	914-1092mm	75
	≤ 29%*		100*
60kg 90UTS	≤ 72%	914-1092mm	100
60kg R260	≤ 72%	914-1092mm	100 [#]
60kg 1175HT	≤ 72%	914-1092mm	100 [#]

(b) 22.32t axle load:

Type of Rail	Dynamic Augment	Wheel Diameter (New)	Max Permissible Speed (Kmph)
52kg 90UTS	≤ 47%	914-1092mm	60
60kg 90UTS	≤ 53.5%	914-1092mm	75

Vinod

GUIDELINES FOR NEW WAGON DESIGN

	≤45%*		100*	on Straight and Curve upto 2 degree
			75*	On Curve sharper than 2 degree
60kgR260	≤ 72%	914-1092mm	100#	on Straight and Curve upto 2 degree
		914-1092mm	75#	On Curve sharper than 2 degree
60 kg 1175HT	≤ 72%	914-1092mm	100#	

(c) 22.9t axle load:

Type of Rail	Dynamic Augment	Wheel Diameter (New)	Max Permissible Speed (Kmph)	
52kg90UTS	≤ 47%	914-1092mm	60	
60kg90UTS	≤ 53.5%	914-1092mm	75	
	≤42%*		100*	On Straight and Curve upto 2 degree
			75*	On Curve sharper than 2 degree
60kgR260	≤ 72%	914-1092mm	100#	On Straight and Curve upto 2 degree
		914-1092mm	75#	On Curve sharper than 2 degree
60kg1175HT	≤ 72%	914-1092mm	100#	

(d) 25t axle load

Type of Rail	Dynamic Augment	Wheel Diameter (New)	Max Permissible Speed (Kmph)	
52kg90UTS	--	914-1092mm	Not permitted	
60kg90UTS	≤ 41.5%	914-1092mm	45	
60kgR260	≤ 72%	914-1092mm	60#	Straight and Curve upto 2 degree

Vimk

		914-1092mm	45 [#]	Curve sharper than 2 degree
60kg1175HT	≤ 72%	914-1092mm	100 [#]	

*Proposed parameter for new rolling stock to permit speed of 100 kmph.

#Proposed maximum permissible speed

Note:

Any deviation of above parameters may further require to review the maximum permissible speed.

Present speed of 75kmph, 60Kmph for axle load of 20.32t, 22.32t/22.9t respectively on 52Kg (90 UTS rail) is not on account of 914-1092mm diameter of wheel. There shall be no speed restriction upto 23t axle load on account of 914-1092mm diameter of wheel on 880grade rail (as per IRS-T-12-2009 specifications), However, there may be speed restriction on account of combined bending/residual stress.

- (E) For new wheel diameter of 840mm, the boundary conditions in accordance with wheel base of 2.0m and Bogie Centre distance as per IRSOD, revised 2004 for given maximum permissible speed for different axle loads may be as follows:

Minimum diameter on tread on new wagon wheel measured at 63.5mm from wheel gauge face as 840mm may be permitted subject to speed restriction of 65kmph for axle load of more than 22t & up to 23t and speed restriction of 45kmph for axle load more than 23t & up to 25t on curves sharper than 875m radius on Grade 880 rail (as per IRS-T-12-2009 specifications) loaded wagon subject to limit of maximum wheel flat as 50mm. However, there shall be no such restrictions of speed on 1175HT grade rails. For other rail grades and wheel diameters separate study will be required.

- (F) The minimum hardness of 52kg/60kg 90UTS rail is 260 BHN, 60kg R260 rail is 260-300BHN and 60kg 1175HT rail is 350-390BHN

Vimk

SCHEDULE - C: Stipulation of Boundary Conditions of Bridge

1. The bridges on IR have been designed for BGML (1926), RBG (1975), MBG (1987), CC+8+2 (not a Standard loading), HM Loading (2000), 25t (2008). Bridges older than 1926 have been designed for maximum axle load less than that in BGML. Thus loads on bridges have been increased on five occasions in about 100 years. Further, there is a demand for interoperability of rolling stocks designed for DFC on IR network also. This may call for even higher loading (32.5t) at subsequent stages.
2. Broadly loads considered in bridge design are Dead load, Live loads, Seismic loads, windloads, etc. Dead load is weight of the bridge. Seismic loads and Wind loads are broadly guided by BIS Codes. Live load is train load. Thus, Loads and Rolling Stock parameters of concern are-
 - a) Seismic Loads - Provisions of BIS Codes and IRS Codes are followed.
 - b) Wind Loads - Provisions of BIS Codes are followed.
 - c) Train loads - Axle loads, spacing of axles, Tractive and Braking forces, Trailing Load
Density, Impact loads.
 - d) Rolling Stock Parameters - Height of center of gravity of wagons, suspension characteristics, CDA, etc.
3. IRS Bridge Rules specify the loads for design of super-structure and sub-structure of bridges and for assessment of the strength of existing bridges. IRS Bridge Rule specifies Equivalent uniformly distributed load (EUDL), Coefficient of Dynamic augments(CDA) values and longitudinal forces for Broad Gauge Standard Loadings (BGML)-1926, Revised Broad gauge loading (RBG)-1976, Modified Broad gauge loading (MBG)-1987 and 25t-2008 loading . The loads specified therein shall be taken into consideration in calculating the strength of all bridges. For checking the adequacy of Existing Bridges for higher Bridge Loading Standards/higher axle loads, the Bending Moments and shear Forces shall be calculated on the basis of EUDLs specified for different Loading Standards. In case it is found inadequate, calculation shall be done on the basis of actual train axle loads with the help of software "Moving Load" issued by RDSO. Para 2.5.3(b) of IRS bridge rule specifies the CG height should be upto 1830 mm for BG stocks.
4. Para 28 of The Railway opening for Public carriage of passenger rule, 2000 specifies that "No new type of engine or rolling stock which would cause stresses exceeding those specified in the IRS Bridge Rules, 1964, or the Standard Codes of Practice, or in the absence of any such reference, the design criteria approved by the Central Government for existing structures or excessive stresses in track shall be ordered until the sanction of the Central Government has been received through the Commissioner for doing so."
5. To avoid unsuitability of bridges during its lifespan, broad parameters of Rolling stock design must be kept within limits of Maximum axle load, trailing load density, axle spacing, height of center of gravity of rolling stocks, tractive & braking forces, and limits of impact loads.

For optimal utilization of existing RDSO standard span Bridge infrastructure over IR BG network for standard loading following boundary parameters may be used in design of wagons:-

Vimk

Wagon Axle configuration:

Where:-

- a: Distance between first buffer to centre of first wheel
- b: Spacing between center of first wheel to center of second wheel
- c: Distance between center of second wheel to center of third wheel
- d: Spacing between center of third wheel to center of fourth wheel
- e: Distance between center of last wheel (fourth wheel) to last buffer

The boundary parameters for Wagon design are defined by considering most restrictive existing Motive Power unit (double headed WDG6G) with limiting maximum tractive effort by 30.5t. Any future restrictive locomotive (increase in axle load and/or change in axle configuration on lower side) may call for speed restriction or prohibition on bridges. Maximum Braking force at Rail level should not exceed 10% of axle load of Wagon.

Values of a,b,c,d & e for different speed and axle load should be as below:

(i) 25t axle load wagon for 60kmph operation.

CG height	a	b	c	d	e	Total length
Upto 1830mm	≥1.5m	≥2m	≥5.10m	≥2m	≥1.5m	≥12.10m
1830-2000mm	≥1.5m	≥2m	≥5.25m	≥2m	≥1.5m	≥12.25m
2000-2100mm	≥1.5m	≥2m	≥5.35m	≥2m	≥1.5m	≥12.35m

Note: Any deviation in above parameters in design of wagon may call for speed restriction or prohibition on bridges.

(ii) 25t axle load wagon for 75kmph operation.

CG height	a	b	c	d	e	Total length
Upto 1830mm	≥1.5m	≥2m	≥5.47m	≥2m	≥1.5m	≥12.47m
1830-2000mm	≥1.5m	≥2m	≥5.65m	≥2m	≥1.5m	≥12.65m
2000-2100mm	≥1.5m	≥2m	≥5.8m	≥2m	≥1.5m	≥12.80m

Note: Any deviation in above parameters in design of wagon may call for speed restriction or prohibition on bridges.

Vimk

(iii) 22.9t axle load wagon for 75kmph operation.

CG height	a	b	c	d	e	Total length
Upto1830mm	≥1.5m	≥2m	≥4.36m	≥2m	≥1.5m	≥11.36m
1830-2000mm	≥1.5m	≥2m	≥4.55m	≥2m	≥1.5m	≥11.55m
2000-2100mm	≥1.5m	≥2m	≥4.65m	≥2m	≥1.5m	≥11.65m

Note : Any deviation in above parameters in design of wagon may call for speed restriction or prohibition on bridges.

(iv) 22.9t axle load wagon for 100kmph operation.

CG height	a	b	c	d	e	Total length
Upto1830mm	≥1.5m	≥2m	≥ 4.935m	≥2m	≥1.5m	≥ 11.935m
1830-2000mm	There may be speed restrictions/ prohibitions on some of standard span bridges					
2000-2100mm	There may be speed restrictions/ prohibitions on some of standard span bridges					

Note : Any deviation in above parameters in design of wagon may call for speed restriction or prohibition on bridges.

(v) 22.32t axle load wagon for 75kmph operation.

CG height	a	b	c	d	e	Total length
Upto1830mm	≥1.5m	≥2m	≥4.1m	≥2m	≥1.5m	≥11.10m
1830-2000mm	≥1.5m	≥2m	≥4.25m	≥2m	≥1.5m	≥11.25m
2000-2100mm	≥1.5m	≥2m	≥4.4m	≥2m	≥1.5m	≥ 11.4m

Note: Any deviation in above parameters in design of wagon may call for speed restriction or prohibition on bridges.

Vimh

(vi) 22.32t axle load wagon for 100kmph operation.

CG height	a	b	c	d	e	Total length
Upto1830mm	≥1.5m	≥2m	≥4.65m	≥2m	≥1.5m	≥11.65m
1830-2000mm	There may be speed restrictions/ prohibitions on some of standard span bridges					
2000-2100mm	There may be speed restrictions/ prohibitions on some of standard span bridges					

Note : Any deviation in above parameters in design of wagon may call for speed restriction or prohibition on bridges.

(vii) 20.32t axle load wagon for 75kmph operation.

CG height	a	b	c	d	e	Total length
Upto1830mm	≥1.5m	≥2m	≥3.1m	≥2m	≥1.5m	≥10.10m
1830-2000mm	≥1.5m	≥2m	≥3.25m	≥2m	≥1.5m	≥10.25m
2000-2100mm	≥1.5m	≥2m	≥3.35m	≥2m	≥1.5m	≥10.35m

Note: Any deviation in above parameters in design of wagon may call for speed restriction or prohibition on bridges.

(viii) 20.32t axle load wagon for 100kmph operation.

CG height	a	b	c	d	e	Total length
Upto1830mm	≥1.5m	≥2m	≥3.65m	≥2m	≥1.5m	≥10.65m
1830-2000mm	There may be speed restrictions/ prohibitions on some of standard span bridges					
2000-2100mm	There may be speed restrictions/ prohibitions on some of standard span bridges					

Note: Any deviation in above parameters in design of wagon may call for speed restriction or prohibition on bridges.

6. The permissible speeds of some of the existing wagons are given below as sample. This is to emphasise the point that boundary conditions have to be met for maximum permissible speeds as above and any deviation may cause speed restrictions/ prohibition on the some spans.

List of 22.32/22.9t wagon checked w.r.t. 75kmph speed

S N	Wagon	Axle load (t)	C.G. Height (mm)	Speed potential (kmph) on RDSO standard span w.r.t. 75kmph in loaded condition					a	b	c	d	e	
				BGML/MBG		RBG								
				Upto 47.25 m	63.0 m & 78.8 m	Upto 31.9 m	47.25 m	63.0 m						78.8 m
1	BCNAHSM1	22.82	1919	75	60	75	75	60	60	1.475m	2.0m	7.500m	2.0m	1.475m
2	BOXNHSM2	22.82	1917	75	60	75	75	60	60	1.0945m	2.0m	4.524m	2.0m	1.0945m
3	BOXNHL	22.9	1998	75	60	75	75	60	55	1.1365m	2.0m	4.690m	2.0m	1.1365m
4	BOXNHA	22.82	1661	75	60	75	75	60	50	1.0945m	2.0m	4.524m	2.0m	1.0945m
5	BOBRNHSM2	22.32	2390	75	60	75	70	55	45	0.905m	2.0m	4.790m	2.0m	0.905m

Vimb

SCHEDULE - D: Stipulation of Boundary Conditions of Signalling

1. Provisions of GR, SR, IRSOD, SEM & all extant instructions issued from time to time as applicable shall be complied with.
2. While running through a station yard, speed of the Rolling stock shall be restricted to the maximum permissible speed as per standard of interlocking provided at the station or any other speed restriction whichever is severe.
3. In case of wagons having EBD of more than 1 Km and provision of second distant signal in absolute block working territory/4 Aspect signalling in automatic block working territory (as laid down in para 7.1.13 (b) & 7.1.15 of IRSEM) is not available then a suitable speed restriction shall be imposed to bring EBD within 1 kms.
4. In case electromagnetic compatibility (EMI/EMC) test with S&T equipment is required due to design of wagon, then same may be ensured before introduction of normal running of the said rolling stock.

Vimk

SCHEDULE - E: Stipulation of Boundary Conditions of OHE

For Boundary condition of OHE for operation of Wagons, following Paras of IRSOD (BG)- Revised 2004 should be referred:

1. Chapter V-A Electric Traction 25KV AC, 50 Cycles of Schedule-I regarding Electrical Clearances, Minimum height of Contact wire, Stagger of contact wire, Maximum Pantograph width.
2. Chapter V-B Electric Traction 25KV AC, 50 Cycles with High Rise OHE of Schedule-I regarding Minimum height of Contact wire, Minimum Height of Overhead Structure, Clearances for power line crossings & Maximum Pantograph width.
3. Appendix for Extra clearances on curves & Appendix A to Chapter V-A for Clearances required for 25 KV single phase A.C. Electric Traction.
4. Para 7 & 8 of Schedule-I, Chapter I regarding Minimum Horizontal distance from center of Track to any structure.
5. Para 10 of Schedule-I, Chapter I regarding Height of Road Over Bridge and Foot Over Bridge.
6. Para 11 of Schedule-I, Chapter I regarding Clearances for Power line crossing including telephone line crossing of Railway Tracks.

Vimukta

Annexure A1- Indian Railways Schedule of Dimensions (IRSOD)- 2021

(64 pages)

Vink



INDIAN RAILWAYS
SCHEDULE OF DIMENSIONS
1676mm Gauge
(BG)

Revised, 2021

Vinod

FOREWORD TO IRSOD (BG) REVISED, 2021

Indian Railways Schedule of Dimensions, 1676 Gauge, BG, Revised- 2004 was published in year 2004. After this, there have been a number of Correction Slips issued so far (i.e. Advance Correction Slip Nos. 1 to 32). It was, therefore, considered necessary to reprint Indian Railways Schedule of Dimensions (BG) (IRSOD) duly incorporating all changes after previous version. This reprint incorporates Advance Correction Slips No.upto32.

It is expected that this updated IRSOD will be of immense use to all the officials in easily accessing latest instructions related to Schedule of Dimensions, 1676 Gauge, BG.

Additional Member/Civil Engineering
Ministry of Railways, Railway Board
Rail Bhawan, New Delhi-110001

Vimk

Viank

PREFACE

SCHEDULE OF DIMENSIONS-1676mm GAUGE

Schedule of Dimensions for Indian Railways, 1676mm Gauge

Dear Sir/Dear Sirs,

With their circular letter No. 735-W. of 1922, the Railway Board issued a Schedule of Maximum, Minimum and Recommended Dimensions to be observed on all 1676mm gauge Railways in India. In that Schedule, certain dimensions of the previous schedule of the year 1913 were modified with the object of permitting the use of enlarged rolling stock.

2. The Schedule of Dimensions of 1922 contained two distinct sections, namely, a schedule of "Maximum and Minimum Dimensions" which was considered to enable the proposed larger vehicles to run with about the same degree of safety as that which was previously obtained on the older Railways with existing stock, and a schedule of "Recommended Dimensions" intended to provide approximately the same clearances from fixed structures for the future larger vehicles as the 1913 schedule gave for existing vehicles.
3. In their circular letter No. 232-Tech., dated the 8th February, 1926, the Railway Board gave instructions that the Recommended Dimensions given in the 1922 Schedule were to be observed on important Railways in all new works and alterations to existing works. These orders were modified in letter No. 232-Tech. of the 26th April, 1926, which allowed a relaxation in the case of certain recommended dimensions, the adoption of which would involve heavy expenditure in remodeling works.
4. In 1929, it was found desirable further to amend the Schedule of 1922 in order to introduce certain improvements in the light of experience gained since it was issued, and to provide the clearances required by electric traction equipment on lines which were likely to be electrified in the future. A few special dimensions were also required for "Standard C" railways as defined in the "Rules for preparation of Railway Projects 1926 - Chapter III, Standards of Construction".
5. The Schedule I issued in 1929, therefore, embodied these amendments and additions and the opportunity was taken to omit from this schedule many dimensions occurring in the 1922 Schedule and its predecessors which were more of the nature of current practice than essential for safe working. These were therefore, relegated to Schedule II, Recommended Dimensions.
6. Among the more important changes introduced in the 1929 Schedule, were an increase in the minimum height above rail level for overhead structures to 5410mm and increase to 2360mm in the horizontal distance to a fixed structure up to 3355mm above rail level, a reduction in this distance to 2135mm at 4420mm above rail level, and a reduction also in the clearance to fixed structures from rail level to 1065mm above rail level on bridges and in tunnels. The last three changes were intended to allow for a reduction in tunnel sections and an improvement in the disposition of bracing of bridge girders without sacrificing safety.
7. In 1936, however, the financial stringency on Railways brought to the front the urgent necessity for restricting capital expenditure to a minimum. The falling off in Railway traffic generally and the increasing demand for light fast units to compete with motor bus transport also made the introduction of heavier engines and 3660mm wide stock on Railways improbable. In these circumstances it was found desirable to alter the dimensions prescribed in Schedule I of the 1929 Dimensions and to revert to the maximum and minimum dimensions in the 1922 Schedule in several important respects. Railway administrations were advised of these alterations through correction slip no. 14 of 1st December, 1936 to the 1929 Schedule. These alterations were not, however, intended to prevent the introduction of 3660mm stock at some future date, should this prove necessary. It had, therefore, been expressly laid down that the modifications made in Chapter I of Schedule I, were not to apply to Tunnels, Through and Semi-through Girder Bridges in respect of which the Standard Dimensions of 1929 would continue to apply.

Vinoh

Vimuk

8. The Schedule of dimensions, with metric and F.P.S dimensions which was forwarded in the year 1973 was based on the 1958 reprint of 1939 schedule, with the difference that the Chapter IV and IV SS of schedule – I, were combined and rearranged under two headings viz chapter IV (A), for carriage and wagon and chapter IV(C) for locomotive and the dimensions pertaining to 3050mm wide bogie stock were omitted from this version of 1973 schedule. Chapter IV-S relating to 3660mm wide stock were designated as chapter IV (B) for carriage and wagon. In converting F.P.S dimensions into metric, the dimensions of “wheel profile” were rounded off to the nearest 0.50mm, diameter of wheel and smaller dimensions less than 12 inches rounded off to the nearest mm, those of fixed structures and profile of rolling stock to the nearest 5mm and other larger dimensions to the nearest cm in metric unit depending on the accuracy required. Schedule II & III, showing Recommended Dimensions and Infringements of Schedule I respectively, which might be permitted on existing railways, were retained and the appendix dealing with extra clearances required on curves were revised to show the clearances required for 3250mm wide and 21340mm long rolling stock. Also in the revised table, the maximum permissible speed and corresponding super-elevation were indicated and the required clearances based on these super elevations were given.
9. The dimensions prescribed in Schedule I which were essential for safe working, were applicable to all new railways and to new works on existing railways, including, so far as practicable, alternations and renewals, and sanction was required to a departure from them.

The clearances prescribed in item 13 of Chapter I ‘Tunnel, through and semi-through girder bridges’ was to be adopted for all structures, and not only for tunnels and through girder bridges at the time of new constructions or additions/alterations to the existing structures. If, however in case where 3660mm stock was not expected to be introduced, and adoption of these dimensions would entail heavy expenditure, administrative reference to be made to the Board, individually in each case before execution of the work, for adopting less clearance.

10. The schedule of dimensions of 1973 version was based on the requirements of 25KV.A.C. traction and all future construction were to be carried out to these dimensions except in cases where it was considered that there was no chance of the line being subsequently converted to 25KV A.C. traction. A new chapter VA was added in respect of dimensions required for electric traction with 25KV A.C. 50 cycles.
11. The Indian Railways schedule of dimensions (BG) Revised, 2004 was a revised version of the Schedule of Dimensions of 1939 reprinted in 1973. The subject of review of B.G. Schedule of Dimensions 1939 reprinted in 1973 was discussed under item No. 821 of 64th Track Standards Committee meeting held in March 1990. Based upon the committee’s recommendation on this item, Railway Board vide their letter no. 90/CE-II/TSC/1 dated 17.12.99 issued orders to Director General/RDSO to appoint a multi disciplinary committee for the revision of Schedule of Dimensions (1973 reprint). The Multidisciplinary committee consisted of the following directorates of RDSO:
 - i) Track Design Directorate (Co-ordinating Directorate)
 - ii) Bridges & Structures Directorate
 - iii) Carriage Directorate
 - iv) Motive Power Directorate
 - v) Wagon Directorate
 - vi) PS & EMU Directorate
 - vii) Signal Directorate
 - viii) TI Directorate

Vink

The Indian Railways schedule of dimensions (BG) Revised, 2004 consisted of only metric units. All dimensions in FPS units were deleted. The following modifications were done in Indian Railways schedule of dimensions (BG) Revised, 2004 over the structure of schedule of dimensions of 1973

- (a) Only two schedules - Schedule I & Schedule II, are provided in this revised Schedule of Dimensions. Schedule-I consists of those items which are mandatory and have to be observed on all 1676mm Gauge Railways in India. It is mandatory and contains the items of Schedule-I & certain selected items of Schedule-II of 1973 version of Schedule of Dimensions.
- (b) Schedule-II consists of items included in Schedule -III of 1973 version of Schedule of Dimensions.
- (c) For maximum moving dimensions, profile shown in diagram 1D (EDO/T-2202) was adopted which is based on the two profiles viz. EDO/T-1043 (for goods stock and locomotives) and sketch 72227 (for double Decker coach) which was approved by Railway Board vide their letter no. 72/WDO/SR/31 dated 21.2.1974 & 60/WDO/SR/19 dated 5.8.92 respectively.
- (d) The diagrams of Schedule of Dimension reprint 1973 was suitably modified by replacing profile with profile (diagram 1D).
- (e) The appendix dealing with extra clearances required on curves was modified to suit maximum speed of 160 kmph with maximum super-elevation of 165mm and 100mm cant deficiency as per high speed Rajdhani and Shatabdi Routes, with other parameters kept as earlier. Additional appendix for extra clearances required on curves for maximum speed upto 200 kmph was also included in the in the Indian Railways Schedule of Dimensions (BG) Revised, 2004.
- (f) Various correction slips issued from time to time to Schedule of Dimensions of Reprint, 1973 was incorporated in the Indian Railways Schedule of Dimensions (BG) Revised, 2004.

12 Railway Board vide letter no. 2012/M(N)/951/14 dated 1 21.10.2021 and 7.11.2021 has directed that many amendments has been issued to Indian Railways Schedule of Dimensions (BG) Revised, 2004, therefore there is a need to issue revised IRSOD. Accordingly, various correction slips issued from time to time to Indian Railways Schedule of Dimensions (BG) Revised, 2004 as listed in Annexure-III and minimum wheel diameter of 840mm for goods vehicle along with minimum floor height /coupler & CBC height and maximum diameter of 1250mm for locomotive (repeated condonation) have been incorporated in this Indian Railway Schedule of Dimensions(BG), Revised – 2022.

Additional Member/Civil Engineering
Ministry of Railways, Railway Board
Rail Bhawan, New Delhi-110001

Vimh

SCHEDULE – I
STANDARD DIMENSIONS
1676mm GAUGE (BG)
CHAPTER I – GENERAL

The DIMENSIONS given in this Schedule-I have been classified under two heads namely for 'Existing works' and for 'New works'. Existing works means the works which were existing before issue of this Schedule of Dimensions (2004) and would help the field engineers to provide the information about previous dimensions followed at one place.

New works would include altogether new constructions, additions of new lines, new structures, gauge conversion and doubling. However, it does not include the works of alteration such as shifting of a Points and Crossings, extension of siding, extension of loop line, alteration in building etc.

The dimensions, except for existing works, are to be observed on all 1676 mm gauge on Indian Railways for execution of new works. Provided that infringement to any provision of IRSOD Chapter I, II, III, V, VA & VB of Schedule I can be condoned by the Commissioner, provided further that infringement beyond the limits prescribed in Schedule II, if any, or wherever specific mentions appear in Schedule I, sanction for condonation shall be obtained from Railway Board through Commissioner/Chief Commissioner of Railway Safety.

[See Diagram Nos. 1A,1A(Modified),1B,1C and 1D]

NOTE:

- (1) Items 8 and 10 are applicable only to structures outside station yards. All other items are of general applicability.

For running EMU and other 3660mm Stock on existing works, clearances prescribed in items 13(i) (a) and (ii) of Chapter I "Tunnels, Through and Semi Through, Girder Bridges" shall also be required for all structures governed by items 1(i), 7(i), 8(i) and 12 of this chapter and not only for tunnels, through and semi through girder bridges.

Spacing of Tracks:-

1	Minimum distance center to center of straight tracks	
	(i) For existing works	4265mm
	(ii) For new works/addition to existing works	5300mm

- Note:** (a) See Appendix for extra clearance required on curves.
(b) For spacing of tracks in tunnels, Road Over Bridges/Flyovers, through and semi through girder bridges, see item 13.

Vink

- (c) New/Additional works cover laying of new line and new running loops. Extension of existing line or replacement of points & crossings will not be treated as new work.
- (d) OHE mast and Signal post shall not preferably be provided in between tracks. However, under unavoidable circumstances, the clearances mentioned in para 1(ii) above shall be increased by equal to the width of such provisions/structures/foundation, as the case may be.
- (e) In case of tunnels, ROBs, flyovers, through & semi-through girder bridges, where center to center distance lesser than 5300mm between tracks has been provided, lesser center to center distance between tracks can be provided on approaches also up to adequate distance to facilitate gradual increase in center to center distance up to minimum 5300mm.
- (f) Further, in case lesser than 5300mm center to center distance between tracks has been provided in the existing station yard, lesser center to center distance between tracks can be provided on approaches towards block section also, up to adequate distance to facilitate gradual increase in centre to centre distance up to minimum 5300mm.

Curves:-

- | | | |
|---|--------------------------|-------------------|
| 2 | Minimum radius of curves | 175m (10 degrees) |
|---|--------------------------|-------------------|

Bridges:-

- 3 Bridges must conform to the requirements of chapter IV of the Railways opening for the Public carriage of Passengers, Rule 2000.

On existing bridges where there is nothing solid between sleepers to prevent a derailed wheel dropping, the clear distance between two consecutive sleepers shall not exceed 510mm. The clear distance between the joint sleepers shall not, however, exceed 200mm and that between the two consecutive sleepers 450mm in all new constructions and in existing bridges when regirdering or carrying out through sleeper renewal.

Bridge sleepers resting directly on longitudinal girders should not be less than 150mm deep exclusive of any notching which may be required to allow for cover plates, camber, etc and not less than 305mm greater in length than the distance outside to outside of girder flanges subject to a minimum of 2440mm. The minimum length of steel trough sleepers should be the distance outside to outside of girder flanges subject to a minimum of 2440mm

Rails:-

- | | | |
|---|--|-----|
| 4 | Minimum clearance of check rails for a curve | 44m |
|---|--|-----|

Note: (a) This clearance must be increased by not less than half the amount of any difference between 1676mm and the gauge to which the curve is actually laid.

(b) Check rail to be provided in curves where the radius is 218 metres or less i.e. curvature is 8° or more. They may be necessary also in the case of flatter curves, if high speed is contemplated.

- | | | |
|---|--|------|
| 5 | (i) Minimum clearance of check rail at a level crossing | 51mm |
| | (ii) Maximum clearance of check rail at a level crossing | 57mm |

Vink

6 Minimum depth of space for wheel flange from rail level 38mm

Buildings and structures:-

7 Minimum horizontal distance from centre of track to any structure from rail level to 305mm above rail level

- (i) For existing works 1675mm
(ii) For new works or alterations to existing works 1905mm

8 Minimum horizontal distance from centre of track to any structure except a platform

- (i) For existing works
From 305mm above rail level to 4420mm above rail level 2135mm
- (ii) For new works or alterations to existing works
- (a) From 305mm above rail level to 1065mm 1905mm increasing to 2360mm
(b) From 1065mm above rail level to 3355mm 2360mm
- (c) From 3355mm above rail level to 4420mm 2360mm decreasing to 2135mm
(d) From 4420mm above rail level to 5870mm 2135mm decreasing to 915mm

Note:

- (a) Under item 7 and 8, any material stacked by the side of line is to be considered a structure in the sense in which the word is used here. These items also apply to projections of rock etc., from the side of cutting.
- (b) See appendix for extra clearance required on curves.
- (c) Light structures such as ladders, thin posts etc. erected alongside the track at a distance of less than 2360mm from centre of adjacent track should be blanked off to a height of 300mm between 2060mm and 2360mm above rail level.

- (iii) (a) Below the rail level up to the formation level of the track on straight and curves up to radius of 875m 2575mm
(b) Below the rail level up to the formation level of the track on curves with radius less than 875m 2725mm

Note:

- (a) The required clearances as mentioned under item 8 (iii) (a) and (b) above will be applicable in case of new lines/doubling/electrification.
- (b) The various fixture which are attached to the track like traction bonds etc. and are required to be fitted with the rail can be provided and the clearance as mentioned in item 8 (iii) (a) & (b) above will not be applicable to these fixtures.
- (c) The clearances as mentioned in item no. 8 (iii) (a) and (b) above will not be applicable in case of bridges, tunnels & ballastless track (including washable apron).

Vimukh

9 Minimum horizontal distance of any telegraph post measured from the centre of and at right angles to the nearest track.

- | | | |
|------|--|---------------------------------------|
| (i) | For existing works | The height of the post plus
2135mm |
| (ii) | For new works or alterations to existing works | The height of the post plus
2360mm |

Note: When the line is in cutting a telegraph post erected outside the cutting, must be at a distance from the edge of the cutting not less than the total height of the post.

10 Height of Road Over Bridges & Foot Over Bridges:

- | | | |
|-----|--|--------|
| (a) | Minimum height above rail level for a distance of 915mm on either side of the centre of track for overhead structures | 4875mm |
| (b) | Where D.C. electric traction is in use or is likely to be used, this dimension shall be | 5410mm |
| (c) | Where 25 KV A.C. traction is likely to be used, the minimum height above rail level for a distance of 1600mm on either side of the center of track shall be as under : | |
| | (i) Light Overhead structure, such as Foot Over Bridges | 6250mm |
| | (ii) Heavy Overhead Structure, such as Road Over Bridges and Flyovers | 5870mm |

Note:

- (a) See appendix for 'extra clearance required on curves'.
- (b) In case of restricted height of existing structures, a special study shall be made, as indicated in Appendix-A to Chapter V-A before 25 kV A.C. traction is introduced. Accordingly, only in such cases, the minimum height above rail level shall not be lower than 5070mm in case of Heavy Overhead Structure (such as Road Over & Flyovers) and 5270mm in case of Light Overhead Structures (such as Foot Over Bridges) for a minimum contact wire height of 4800mm from above rail level. OHE arrangements shall be as per RDSO Drawings.
- (c) In areas where 25 kV A.C. traction is used or likely to be used, if any turnout or crossover is located under a heavy overhead structure or within 40m from its nearest face, irrespective of the position of level crossing gate, the minimum height of such overhead structure shall be 6250mm*. In case the turnout is beyond 40m; but the level crossing gate is within 520m from the nearest face of the bridge, the height of such overhead structure shall be 6250mm*.
- (d) The height mentioned against items 10(a), 10(b) & 10(c) above shall be measured from the higher or superelevated rail.
- (e) On lines, existing or proposed to be electrified on 25kV A.C. system, necessary provision shall be made in overhead structure and overhead equipment, if necessary, by using longer traction overhead equipment masts to permit an extra allowance of 275mm for raising of track in future to cater for modern track structure in the form of increased ballast cushion, larger sleeper thickness and deeper rail sections.

Vimby

* In case of restricted height of existing heavy overhead structure, minimum height above rail level shall not be lower than 5270mm, adhering to the provisions of note (b) above.

(f) For Mumbai Suburban, the height of Foot Over Bridges mentioned under para 10(c)(i) above may be reduced to 5750mm subject to following conditions:

- (i) The minimum height of the contact wire shall be 4800 mm.
- (ii) A special study shall be conducted as indicated in appendix A of chapter V-A to ascertain the feasibility of the contact wire height as 4800mm.
- (iii) There shall be no crossover below FOB or within 40 m from the face of FOB.
- (iv) There shall be no level crossing within 520 m from face of FOB.
- (v) The maximum height of rolling stock shall be restricted to 4420 mm.
- (vi) The height shall be measured from the higher or super-elevated rail.

11. Clearance for Power line crossings including Telephone line crossings of Railway Tracks –

11(i) Clearances for Power line crossings in Non-Electrified & Electrified Territory:

SL	Over head crossing voltage	Minimum clearances from Rail Level		Minimum clearance between highest Traction Conductor and lowest Transmission line crossing conductor
		Existing power line crossing for Non-Electrified Territory	New power line crossing or crossing planned for alteration	
(1)	(2)	(3)	(4)	(5)
1.	Upto and including 11kV	Normally by underground cable		
2.	Above 11kV & upto 33kV	10860 mm	14660 mm	2440 mm
3.	Above 33kV & upto 66kV	11160 mm	14960 mm	2440 mm
4.	Above 66kV & upto 132kV	11760 mm	15560 mm	3050 mm
5.	Above 132kV & upto 220kV	12660 mm	16460 mm	4580 mm
6.	Above 220kV & upto 400kV	14460 mm	18260 mm	5490 mm
7.	Above 400kV & upto 500kV	15360 mm	19160 mm	7940 mm
8.	Above 500kV & upto 800kV	18060 mm	21860 mm	7940 mm

Note :

- (i) All height/clearances are in mm and under maximum sag conditions.
- (ii) If the crossing is provided with a guarding, a minimum clearance of 2000mm shall be maintained between bottom of guard wire and highest traction conductor.
- (iii) Power line crossing in yards and stations area shall be avoided.
- (iv) For any electrification work of existing track/railway line, new track/line, multiple track/railway line and doubling/gauge conversion of railway line/track along with electrification, existing power line crossings can continue, if dimensions are as per column (5) above, even if dimensions of column (3) are not satisfied i.e., for electrification works column (3) is not applicable. Further, in case of any electrification work on

new line existing power line crossings can continue, if dimensions are as per column (5) above, even if dimensions of column (3) are not satisfied i.e., for electrification works column (3) is not applicable

- 11(ii) Minimum clearance between any conductor not adequately insulated and any railway structure under most adverse conditions.

SL	Voltage	Minimum Clearance
(1)	(2)	(3)
(a)	Upto and including 650 volts	2500mm
(b)	Above 650 volts and upto & including 33 kV	3700mm
(c)	Above 33 kV and upto & including 66 kV	4000mm
(d)	Above 66 kV and upto & including 132 kV	4600mm
(e)	Above 132 kV and upto & including 165 kV	4900mm
(f)	Above 165 kV and upto & including 220 kV	5500mm
(g)	Above 220 kV and upto & including 400 kV	7300mm
(h)	Above 400kV and upto & including 500 kV	8200mm
(i)	Above 500 kV and upto & including 800 kV	10900mm

- 11(iii) Minimum height above rail level for telegraph, telephone and other such low tension wires crossing a railway 6100mm

- 11(iv) Minimum Horizontal Distance of Structures:

The minimum horizontal distance measured at right- angle to, and from the centre of nearest track to any part of the structure above ground level, carrying electrical conductor crossing a railway line shall be:

- (i) For new structure : (H+6) m
(ii) For existing rigid well founded post/structures : 3m, or 1.5m away from the toe of embankment/top of cutting, whichever is more

Where, 'H' is the height of post/structure from nearest ground level

Note :

1. Rigid well founded post/structure: Any post/structure which is so constructed or guyed as to remain in a vertical position, or failing this to continue to provide the minimum horizontal clearances of 2.135m from the centre of nearest track, with one or all of the conductors broken or with its conductors attached, when subjected to maximum wind pressure, shall be considered to be a "rigid well founded post/structure".
The existing rigid well founded post/structures, presently at a distance equal to or more than (ii) as given above, but less than (H+2.135)m, shall be inspected by railway's nominated electrical official once in a year jointly with the owner of the post/structure and certify the safety of the structure, keeping appropriate records of inspections.
2. If the existing post/structure carrying electrical conductors crossing a railway line, is not rigid and well founded then the minimum horizontal distance, measured at right angles from the centre of nearest track, shall be equal to height of post/structure above ground level plus 2.135m.

Interlocking and signal gear:-

Vinoh

- 12 Maximum height above rail level of any part of interlocking or signal gear for a width of 1600mm or 1830mm in the case of tunnels, through and semi-through girder bridges on either side of centre of track subject to the restriction embodied in the note (a) below. 64mm

Note: -

- a) For a distance of 229 mm outside and 140mm inside the gauge faces of the rail, no gear or track fittings must project above rail level except such parts as are required to be actuated by the wheels or wing rails and point rails of special crossings leading to snag dead ends or elevated check rails of crossing or check rails/check flats of diamond crossings.
- b) Signal wires or supports for signal wires may be allowed at not less than 1600 mm or 1830mm in the case of tunnels or through or semi-through girder bridges [see note at item 32 of chapter IV(A)] on either side of the centre of track provided that they are not more than 203mm above rail level.
- c) Metal covers with ramps on both sides must be provided over all interlocking gear projecting above rail level between the rails of a track to prevent hanging couplings from damaging the gear.

Tunnels, Through Girder Bridges and Semi-Through Girder Bridges:

[(See diagram No.1A; 1-A (Modified))]

- 13 (i) Minimum distance at centre to centre of track
- (a) For existing lines 4495mm
- (b) For new works and alterations to existing works 4725mm
- (ii) Minimum horizontal distance from centre of track to any structure shall be as follows:

<u>Height above rail level</u>	<u>Horizontal distance from centre of track</u>
(a) From 0.0mm to 305mm	1905mm
(b) From 305mm to 1065mm	1905mm increasing to 2360mm
(c) From 1065mm to 3355mm	2360mm
(d) From 3355mm to 4420mm	2360mm decreasing to 2135mm
(e) From 4420mm to 5870mm	2135mm decreasing to 915mm

Note:

- (i) Where electric traction is not likely to be used, over-head bracing of bridges may be 5030mm above rail level for a distance of 1370mm on either side of the centre of track.
- (ii) In case of existing structures, a special clearance study shall be made which will be accepted by Electrical Inspector of the Railways, as indicated in Appendix-A to chapter V-A before electric traction is introduced.
- (iii) See Appendix for extra clearances required on curves.
- (iv) Where D.C. traction is in use, Para 13(ii) (e) above shall be as under:
From 4420mm to 5410mm 2135mm decreasing to 915mm
- (v) Tunnels, through girder and semi through girder bridges outside station yards should be treated as heavy overhead structures such as ROB for electrification works and the same dimensions as mentioned in note (c) at para 10 above shall be applicable and OHE arrangement shall be as per RDSO Drawings.

Vimuk

Safety Refuges:

- | | | |
|----|--|-------------------------|
| 14 | Maximum distance apart of refuges in tunnels | 100m |
| 15 | Maximum distance apart of trolley refuges: | |
| | (i) On bridges with main spans of less than 100m | 100m |
| | (ii) On bridges with main spans of 100m or more | A refuge over each pier |

Formation width:

- | | | |
|----|--|---------|
| 16 | Formation width for single line straight track | |
| | (i) For existing works | |
| | (a) Minimum width in embankment | 6850mm |
| | (b) Minimum width in cutting (excluding side drains) | 6250mm |
| | (ii) For new works/alteration to existing works | |
| | (a) Minimum width in embankment | 7850mm |
| | (b) Minimum width in cutting (excluding side drains) | 7850mm |
| 17 | Formation width for double line straight track | |
| | (i) For existing works | |
| | (a) Minimum width in embankment | 12150mm |
| | (b) Minimum width in cutting (excluding side drains) | 11550mm |
| | (ii) For new works/alteration to existing works | |
| | (a) Minimum width in embankment | 13160mm |
| | (b) Minimum width in cutting (excluding side drains) | 13160mm |

Note:

- | | | |
|----|--|--|
| | (a) The minimum formation width is based on: | |
| | (i) Ballast section having 1.5:1 side slope. | |
| | (ii) Cross slope on top of formation of 1 in 30 | |
| | (iii) Track center in case of double line section is 5300 mm | |
| 18 | Formation width on curves: | |
| | (a) Increase due to extra ballast on outside of curves: | |

Vimh

On curves, the actual width to be provided should take into account 150mm extra widening of ballast shoulder (500mm in place of 350mm) required on the outer side of curves. Thus, additions in the width on this account will be 150mm for single line and 300mm for double line.

(b) Increase on double line due to effect of super-elevation:

Due to requirement of extra clearances on double line on curves, increase in track centres with corresponding increase in formation width would be necessary to take into account the effect of super-elevation.

Increase in formation width on curves will be decided after taking into account the increase mentioned in (a) & (b) above.

19. Gauge on straight and curves: The gauge shall be as follows:

(i)	Straight including curves of 350m radius or more	-5mm to +3mm i.e. 1671mm to 1679mm
(ii)	For curves of radius less than 350m	up to +10mm i.e.1686mm

Vimik

CHAPTER II--- STATION YARDS (See Diagram No. 2)

Note:

- (1) The expression "in station" as mentioned in Diagram No. 2 is to be interpreted in accordance with the definition of "station limits" given in chapter I, part I, of the General Rules for open lines, viz "station limits" means the portion of a railway which is under the control of a station master and is situated between the outermost signals of the station.
- (2) For running EMU and other 3660 mm stock, clearances prescribed in item 13(i)(a) and (ii) of chapter I "Tunnel, through and semi-through girder bridges" shall also be required for all structures governed by items 1(i) and 11(A) of this chapter and not only for tunnels and through and semi through girder bridges. However, a platform shelter may infringe item 13(ii) (e) of chapter I and edge of the platform shelter may be kept at a minimum horizontal distance of 1600 mm from centre line of track and at a minimum height of 4610mm above rail level.

Spacing of tracks:-

1	Minimum distance centre to centre on straight tracks	
	(i) For existing works	4265mm
	(ii) For new works/ addition to existing works	5300mm

Note:

- a) See Appendix for 'extra clearance required on curves'.
- b) In case new OHE masts/Signal posts are required to be provided in between tracks under unavoidable circumstances, the clearance maintained in 1(ii) above shall be increased by equal to the width of such provisions/structures/foundations, as the case may be.
- c) For "New Works/additions to existing works such as conversion of existing loop lines into main line, laying of new loop lines and/or shifting of existing lines etc" in the existing yard, if the stipulation mentioned in 1(ii) and Note (c) above are not likely to be achieved due to existing field constraints, then minimum horizontal distance from center of track to any structure, as mentioned in Note (c) of para 11(B) of Chapter-II, IRSOD-2004 shall be ensured.
- d) In completely new yard or portion of existing yard, where "New Work" is being done independent of the existing yard, stipulation under 1(ii) above shall be ensured.
- e) In case of tunnels, ROBs, flyovers, through & semi-through girder bridges, where centre to centre distance lesser than 5300mm has been provided, lesser centre to centre distance can be provided on approaches also up to adequate distance to facilitate gradual increase in centre to centre distance up to 5300mm.

2 Maximum (Steepest) gradient in station yards –

Maximum (Steepest) gradient in station yards, unless special safety devices are adopted and/or special rules enforced to prevent accidents in accordance with approved special instructions.

(i)	For New Works & Alteration to Existing Works-	
	(a) Recommended	: 1 in 1200(0.083%)
	(b) Maximum (Steepest)	: 1 in 400 (0.25%)
(ii)	For Existing works	: 1 in 400 (0.25%)

Note:

Vimk

- (a) Recommended dimension is generally the good practice, the adoption of which will lead to desirable uniformity on Indian Railways; but it is not to be treated as standards, a departure from which requires sanction.
- (b) In case, it is not possible to provide recommended gradient of 1 in 1200 (0.083%) in yard even after making efforts to provide grades as flat as possible, reasons for deviation from recommended gradient and upto the specified maximum (steepest) gradient of 1 in 400 (0.25%) shall be recorded on the ESP. However, for new yards in new line projects adoption of yard gradient steeper than 1:1200 will require approval of General Manager before finalization of ESP.
- (c) No station yard shall be constructed nor shall any siding join a passenger line on a grade steeper than 1 in 100 (1.0%), except where it is unavoidable and then also only with the previous sanction of Railway board, obtained through the Commissioner of Railway Safety, when adequate arrangements are made to prevent accident.
- (d) The powers of condonation for gradient steeper than the specified standard maximum gradient of 1 in 400 (0.25%) shall be as under:

- | | | |
|------|--|--|
| (i) | Existing Yard: | |
| | Steeper than 1 in 400(0.25%) and upto 1 in 100 (1.0%) | : Commissioner of Railway Safety |
| | Steeper than 1 in 100 (1.0%) | :Railway Board through Chief Commissioner of Railway Safety |
| (ii) | For New Yard in New Line Projects: | |
| | Steeper than 1 in 400(0.25%) and upto 1 in 260 (0.38%) | : Commissioner of Railway Safety |
| | Steeper than 1 in 260 (0.38%) | : Railway Board through Chief Commissioner of Railway Safety |

(e) For above purpose, "Station yard" means:

- i) On single line to a distance of 50 m beyond Stock Rail joint of outermost points at either end of the station.
- ii) On double line where 2 Aspect Signaling is provided:
For each line, from Home signal to a distance of 50 m beyond Stock Rail joint of outermost trailing point or 50m beyond Fouling Mark behind heel of crossing of outermost facing point, whichever is farther, or up to Last Stop Signal where there is no point.
- iii) On double or multiple lines where Multiple Aspect Signaling is provided, for each line:
From Block Section Limit Board to Last Stop Signal, where there are no points on that line, else-
From 50 m beyond Stock Rail Joint of outermost facing point or from 50m beyond Fouling Mark behind heel of crossing of outermost trailing point, whichever is farther at reception end; to a distance of 50 m beyond Fouling Mark behind heel of crossing of outermost facing point or 50 m beyond Stock Rail Joint of outermost trailing point, whichever is farther at dispatch end.

- (f) There must be no change of grades within 30 m of any points or crossings.
- (g) In case of "New Lines" projects, the above provisions shall also apply to Flag station, Halt station, or class 'C' station (where there is no station section as defined in IR General Rules, 1976). This is to keep provision for conversion of Flag, Halt, or class 'C' station into class 'A' or 'B' station in future.
- (h) For other than 'New Lines' projects, the above provisions shall not be applicable for Flag station, Halt station, or class 'C' station.

Platforms:

3	(i) Horizontal distance from centre of track to face of passenger platform coping	
	Maximum	1680mm
	Minimum	1670mm

Note :

- (i) The coping of passenger platform must be so constructed that when necessary, to allow for introduction of wider stock, it can be easily and expeditiously set back to 1905 mm. from centre of track (see diagram no. 2)
- (ii) Horizontal distance from centre of track to face of goods platform coping

Maximum	1680mm
Minimum	1670mm
- iii) Horizontal distance from centre of track to face of any platform wall.

Maximum	1905 mm
Minimum	1675 mm

Note:

- (a) New platform walls should be built to maximum dimensions and the coping corbelled out to 1675mm unless provision is made to allow for the introduction of wider rolling stock either by slewing the platform track out by 230 mm or by moving the platform wall 230 mm farther from the track.
- (b) See Appendix for extra clearance required on curves.

4	Height above rail level for high passenger platforms	840mm maximum 760mm minimum
5	Maximum Height above rail level for medium level passenger platform	455mm
6	Maximum height above rail level for goods platforms (except horse and end loading platforms)	1065mm

Note: For items 4, 5 and 6

- (a) Platforms may be flush with rail level.
- (b) The ends of all platforms (except end loading platforms) must be ramped to a slope of 1 in 6 for a width of not less than 1 m from the face of the platform wall, the rest can either be ramped to the same slope or fenced.

Vimh

- (c) The height of platforms serving canted track should be measured vertically from the face to a plane passing through the top of both the rails.
- (d) End loading platforms and platforms on sidings used exclusively for horse loading may be raised to a height of 1295mm above rail level.
- (e) Signal wires or supports for signal wires may be allowed underneath the platform coping.
- (f) The length of a passenger platform should be not less than the length of the longest passenger train excluding the engine, booked to stop at the platform.
- (g) No passenger platform in case of new line, would be constructed on a curve having radius less than 875 meters.
- (h) In case of construction of a new platform on the existing line addition/alteration to existing platforms or in gauge conversion/doubling works, where either the new platform(s) are to be constructed or the old being dismantled and reconstructed, efforts should be made to ease out the existing curves having radii less than 875 m. However, for these works, having platform located/to be located on curves with radii less than 875 m, no condonation of CRS/Board would be necessary.
- (i) For Item 4: the height for Mumbai suburban passenger platform and Pune suburban passenger platform may be in range of 840mm-900mm for reducing gap between bottom of sole bar of EMU coach & platform floor and shall be applicable for operation of EMU stocks having height of bottom of sole bar above rail level not less than 1039mm above rail level in fully loaded condition. The height of platform more than 840mm shall be permitted by General Manager, after ensuring maintenance condition of track and maintenance condition of rolling stock as under:
 - a. Improvement in maintenance practices and monitoring condition of spring during trip inspection of EMU rakes.
 - b. Improvement in track maintenance on platform lines to the standards specified in Para 607(2) of IRPWM.
 - c. Improved monitoring and corrective action to control sinkage of vertical level of track.
 - d. In case, a new design EMU stock, different from the existing stock is to be introduced on suburban section, running trial over increased height suburban platforms shall be required before clearing the stock for passenger operation.

Buildings and structures:

- 7 (a) Minimum horizontal distance of any building/structure on a passenger platform from centre line of track:
- (i) From platform level to 305mm above platform level 5180mm increasing uniformly to 5330mm
 - (ii) From 305mm above platform level to 3430mm above rail level 5330mm
 - (iii) From 3430mm above rail level to
 - (a) 4115mm above rail level in case of existing works 5330mm decreasing uniformly to 3810mm
 - (b) 4610mm above rail level in case of new works or 5330mm decreasing

Vimk

alterations to existing works

uniformly to 3810mm

Note:

- (1) For the return end of platform fencing these dimensions may be reduced to 2740mm.
- (2) Isolated structures are covered in Item 8 below.
- (3) In Mumbai suburban area, when it is not possible to provide platform width to meet provisions at 7.a (i), 7.a (ii) and 7.a (iii) above, the dimensions at 7.a(i), 7.a(ii) and 7.a(iii) can be reduced by Commissioner of Railway Safety for construction of new foot over bridge on the platform, on case to case basis subject to stipulations (a), (b), (c) & (d) below, as under:

- | | |
|--|--|
| (i) From platform level to 3430mm above rail level | 4115 mm |
| (ii) From 3430mm above rail level to 4610mm above rail level | 4115 mm decreasing uniformly to 3810mm |

(a) The supporting column of FOB deck and landing on platform shall be designed in such a way that there is no lateral bracing between two columns up to a height of 2400 mm from platform level to allow free movement of passengers.

(b) The FOB structure as well as platform surface in the 'entire zone covering the members of FOB having horizontal clearance less than 5330 mm from centerline of track from PF level to 2400 mm above PF level' shall be painted with yellow and red retro reflective paint strips to alert the alighting passengers. No temporary or permanent structure, no stabling of hand trolley shall be permitted in this zone. This area shall be well illuminated during night time.

(c) No Slewing of track towards adjoining platform shall be permitted in the FOB zone.

(d) In any case, FOB landing width should not be more than 50% of Platform width.

7 (b) Minimum horizontal distance of any building or longitudinal boundary fence from the centre line of track of passenger platform which is not an island platform (for new works or alterations to existing works):

- | | |
|------------------|---------|
| (i) Minimum | 6830mm |
| (ii) Recommended | 12130mm |

Note:

- (a) Item 7(b) (ii) allows for setting back the platform to make room for an additional track in future, without infringing item 7(b)(i).
- (b) Item 7(b) should also apply to buildings and isolated structures not readily removable, erected on ground over which it is anticipated that a platform may be extended in future.
- (c) Item 7(b)(i) may be reduced to 5330mm in case of foot over bridge at any station and/or provision of longitudinal boundary fence at 'D', 'E' and 'F' category stations; subject to stipulation that if any other pucca construction of building/structure is done in future, provisions of Item 7(a) & 7(b) shall be followed.
- (d) In Mumbai suburban section, for construction of new foot over bridge on the platform, provision of item 7(a) shall be applicable.

Vimk

8 Minimum horizontal distance from centre line of track to a pillar, column, lamp or similar isolated structure on a passenger platform or any building on a goods platform.

- | | | |
|-------|---|---------------------------------------|
| (i) | From platform level to 305mm above platform level | 4570mm increasing uniformly to 4720mm |
| (ii) | From 305mm above platform level to 3705mm above rail level | 4720mm |
| (iii) | From 3705mm above rail level to | |
| (a) | 4115mm above rail level in case of existing works | 4720mm decreasing uniformly to 3810mm |
| (b) | 4610mm above rail level in case of new works or alterations to existing works | 4720mm decreasing uniformly to 3810mm |

8A. Minimum horizontal distance from centre line of track to a pillar, column, lamp or similar isolated structure on goods platforms:

- | | | |
|-------|--|---------------------------------------|
| (i) | From platform level to 305mm above platform level | 3960mm increasing uniformly to 4110mm |
| (ii) | From 305mm above platform level to | |
| (a) | 3980mm above rail level in case of existing works | 4110mm |
| (b) | 4310mm above rail level in case of new works or alterations to existing works | 4110mm |
| (iii) | (a) From 3980mm above rail level to 4115mm above rail level in case of existing works | 4110mm decreasing uniformly to 3810mm |
| | (b) From 4310mm above rail level to 4610mm above rail level in case of new works or alteration to existing works | 4110mm decreasing uniformly to 3810mm |

Note:

A pillar or column(vide items 8 & 8A) which covers more than 3716 sq. cm. in plan, must be classed as "building" and not as " isolated structure".

9 Minimum height above rail level for a width of 1600mm on either side of the centre of track, of tie rods or any continuous covering in a passenger station 6250mm

Note:

- | | | |
|-----|---|--------|
| (1) | On lines other than main lines where 25 kV A.C. electric traction is not likely to be used, the dimensions given above may be modified as under:
For a width of 1370mm on either side of centre of track | 6100mm |
| (2) | On existing primary lines, not likely to be electrified, dimension as in Note 1 may be allowed to Continue | |
| (3) | Item 9 does not apply to over head piping parallel to the track. | |

Vimk

- (4) A low roof that infringes item 9 is permissible in the case of goods or transshipment shed on a siding, provided it does not infringe the out line of the figures for the minimum fixed structure out of stations (see diagram 1B).
- (5) Extra vertical clearance of 275mm under over head structures and overhead equipment in electrified section be provided to allow for any raising of track to permit modern track structure to be introduced.

Note:

On lines proposed to be electrified on 25 kV A.C system, necessary provision should be made in overline structures and overhead equipment if necessary by using longer traction overhead equipment masts to permit possible raising of the track by 275mm in future to cater for increased ballast cushion, larger sleeper thickness and deeper rail sections.

10 Height of Over Head Structures –

Minimum height above rail level for a width of 1600mm on either side of centre of track, of a foot over bridge or a signal gantry in a passenger station 6250mm

Note:

- (a) Where D.C. traction is in use or likely to be used, this minimum height shall be 5410mm.
- (b) On secondary lines, where electric traction is not likely to be introduced, this minimum height shall be 4875mm. This also applies to overhead piping arrangements parallel to track wherever provided, which shall necessarily be changed over to the ground hydrants, when the section is electrified.
- (c) However, for existing overhead structure, dimensions given in note (c) of para 10 of Chapter-I, Schedule -1: General shall be applicable.
- (d) Tunnel, through girder bridge and semi-through girder bridge in station yards shall be treated as heavy over head structures, such as ROB for electrification works and the same dimensions as mentioned in note (c) of para 10 of schedule 1, chapter -1 :General shall be applicable.
- (e) For Mumbai Suburban, the height of Foot Over Bridges mentioned above may be reduced to 5750mm subject to following conditions:
 - (i) The minimum height of the contact wire shall be 4800 mm.
 - (ii) A special study shall be conducted as indicated in appendix A of chapter V-A to ascertain the feasibility of the contact wire height as 4800mm.
 - (iii) There shall be no crossover below FOB or within 40 m from the face of FOB.
 - (iv) There shall be no level crossing within 520 m from face of FOB.
 - (v) The maximum height of rolling stock shall be restricted to 4420 mm.
 - (vi) The height shall be measured from the higher or super-elevated rail.

Vimh

11 Minimum Horizontal Distance from centre of track to any structure:

(A) For existing works:

(i) From rail level to 305mm above rail level	1675mm
(ii) From 305mm to 3355mm above rail level	2135mm
(iii) From 3355mm to 4115mm above rail level	2135mm decreasing to 1980mm
(iv) From 4115mm to 6250mm above rail level	1600mm
(v) Below the rail level and up to formation level of the track on straight and curves up to radius of 875m	2575mm
(vi) Below the rail level and upto the formation level of the track on curves with radius less than 875m	2725mm

Note:

- See appendix for 'extra clearances required on curves'.
- On lines other than main lines or existing main lines, where electric traction is not likely to be introduced, the horizontal distance of 1370mm for height from 4115mm to 6100mm above rail level may be allowed to continue.
- The various fixtures, which are attached to the track like lock bar, point machine, traction bonds, point and signal rodding etc. and are required to be fitted with the rail, can be provided and the clearance, as mentioned in item (v) and (vi) above will not be applicable to these items.
- In case of electrification works in existing yards, no foundation/mast/signal post/any other structure shall be provided between two tracks. In case it is inescapable, the minimum distance of edge of foundation/mast/signal post/any other structure at and above formation level upto rail level from centre of track, shall be 2360mm on straight track & on curve having radius 875m & more and 2510mm in case of curve having radius less than 875m.
- Items (v) and (vi) above shall not be applicable in case of bridges, tunnels and ballastless track (including washable apron).

(B) For New Works or Alteration to Existing works:

(i) From rail level to 305mm above rail level	1905mm
(ii) From 305mm to 1065mm above rail level	1905mm increasing to 2360mm
(iii) From 1065mm to 3735mm above rail level	2360mm
(iv) From 3735mm to 4420mm above rail level	2360mm decreasing to 2135mm
(v) From 4420mm to 4610mm above rail level	2135mm decreasing to 1980mm
(vi) From 4610mm to 6250mm above rail level	1600mm
(vii) Below the rail level and upto formation level of the track on straight and curves upto radius of 875m	2575mm
(viii) Below the rail level and upto the formation level of	

Vink

the track on curves with radius less than 875m.

2725mm

Note:

- (a) See Appendix for 'extra clearances required on curves'.
- (b) Items (vii) & (viii) above shall not be applicable in case of bridges, tunnels, ballastless track (including washable aprons).
- (c) For addition/alteration to works in existing yard the minimum horizontal distance shall be maintained as 2360mm on straight track and on curve having radius 875m & more, and 2510mm in case of curve having radius less than 875m, if it is difficult to provide prescribed clearances as mentioned in items (vii) and (viii) above due to existing field constraints.
- (d) The various fixtures which are attached to the track like traction bonds etc. and are required to be fitted with the rail can be provided and the clearance as mentioned in item (vii) and (viii) above will not be applicable to these fixtures.

Points and crossings.

12 Maximum clearance of check rail opposite nose of crossing 48mm

Note: In case of turnouts laid with 1673mm gauge, the clearance shall be 45mm instead of 48mm.

13 Minimum clearance of check rail opposite nose of crossing 44mm

Note: In case of turnouts laid with 1673mm gauge, the clearance shall be 41mm instead of 44mm

14 Maximum clearance of wing rail at nose of crossing 48mm

Note: In case of turnouts laid with 1673mm gauge, the clearance shall be 45mm instead of 48mm

15 Minimum clearance of wing rail at nose of crossing 44mm

Note: In case of turnouts laid with 1673mm gauge, the clearance shall be 41mm instead of 44mm.

16 Minimum clearance between toe of open switch and stock rail

- (i) For existing works 95mm
- (ii) For new works or alterations to existing works 115mm

Note: The clearance can be increased upto 160mm in curved switches in order to obtain adequate clearance between gauge face of stock rail and back face of tongue rail.

17 Minimum radius of curvature for slip points, turnouts or crossover roads 218 metres (8 degree)

Note: In special cases mentioned below this may be reduced to not less than the minimum of

- i) 213m radius in case of 1 in 8.5 BG turnouts with 6.4m overriding switch, and
- ii) 175m radius in case of 1 in 8.5 scissors crossing to allow for sufficient straight over the diamond crossing between crossovers.

18 Minimum angle of crossing (ordinary) 1 in 16

Note: Crossings as flat as 1 in 20 will usually be sanctioned if recommended by the Commissioner of Railway Safety.

19 Diamond crossings not to be flatter than 1 in 8.5

Note: Diamond crossings as flat as 1 in 10 will usually be sanctioned if recommended by the Commissioner of Railway Safety.

20 Minimum length of tongue rail 3660mm

21 Minimum length of train protection, point locking or fouling treadle bar 12800mm

Note: There must be no change of super elevation(of outer over inner rail) between points 18m outside toe of switch rail and nose of crossing respectively, except in the case of special crossings leading to snag dead-ends or under circumstances as provided for in item – 22.

22 Super elevation and speed in stations on curves with turnouts of contrary and similar flexure:
Main line:- Subject to the permissible run through speed, based on the standard of interlocking, the equilibrium super-elevation, calculated for the speed of the fastest train, may be reduced by a maximum amount of 75mm without reducing the speed on the mainline.

Turnouts:

i) Curves of contrary flexure:-

The equilibrium superelevation in millimeters should be calculated by the formula

$$C = GV^2 / 127R$$

Where

G = Gauge of track + width of rail head in mm

V = Speed in Kmph

R = Radius in m

C = Superelevation in mm

The permissible negative superelevation on the turnout(which is also the actual superelevation of the main line) may then be made as (75-C)mm.

ii) Curves of similar flexure:-

The question of reduction or otherwise of super-elevation on the mainline must necessarily be determined by the administration concerned. In the case of a reverse curve close behind the crossing of the turnouts, the super-elevation may be run out at the maximum of 1mm in 360mm.

Length of sidings:

23 Minimum clear available length of one siding at any station where it is intended to cross trains:-

i) Shall be length of longest train permitted in the section plus 35m

ii) Although it may not be necessary till traffic develops to provide sidings for the largest possible train loads, land should be acquired for them and no building, level crossings or other obstructions should be permitted that will interfere with the crossing siding being lengthened to the following dimensions:-

On sections of the railway where the Ruling gradient is	Minimum clear available length of one siding for new work or alterations to existing works
1 in 100 or flatter	750 m
Steeper than 1 in 100	Length of the longest train permitted in the section plus 35 m

Note : Clear Available length denotes:

- (i) Distance between foot of the signal to Fouling Mark in the rear on the same line in case of Main line and Directional Loop at station yard.
- (ii) In case of Common Loop at the stations, Clear Available Length/Clear Standing Length shall be the distance between two starter signals of opposite direction on the same line.”

CHAPTER III - Workshops and station machinery

Water tanks and water cranes:

1	(a)	Minimum height above rail level for discharge orifice of water crane	3660mm
	(b)	Distance from centre of track to face of tank house less than 60 metres beyond the end of a passenger platform.	
	(i)	Minimum	7165mm
	(ii)	Recommended	11890mm

Note:

(a) Item 1(b) need not be observed in the case of small subsidiary or relay tanks which can easily be removed back to provide room for an extension of the yard.

(b) Item 1(b)(i) allows for the extension of the platform and item 1(b) (ii) allows for the laying of an additional track and extending of the platform in future.

(c) Minimum height for bottom of tank above rail level at water column:

(i)	For watering engines	7620mm
(ii)	For washing engines	12190mm

(d) Minimum total tank capacity at any station 56.5 cu metres or 56825 liters

(e) Minimum internal diameter for piping from tank to water crane 203mm

Workshops and running sheds:

2	Minimum distance from centre to centre of tracks		
	(i)	For existing works	4570mm
	(ii)	For new works or alterations to existing works	
	(a)	In workshops	4570mm
	(b)	In running sheds	5260mm

Note: Where there is a structure between tracks, the distance of centre to centre of tracks is to be increased by the amount of the width of the structure like O.H.E. post etc.

3	Minimum clear distance from centre of track to any isolated structure such as a pillar in:		
	(i)	Workshops	
	(a)	For existing works	2285mm
	(b)	For new works or alterations to existing works	2360mm

Vimk

- (ii) Running sheds 2515mm
 - 4 Minimum clear distance, for a height of 1830 mm above rail level, from centre of track to any continuous structure in
 - (i) Workshops 2745mm
 - (ii) Running sheds 3275mm
- Note:** For standard 'C' Railways, minimum horizontal distance for a height of 1830mm above rail level on either side of centre of track to any continuous structure in running sheds shall be 2745mm.
- 5 Minimum height above rail level to overhead tie bars, girders etc. in workshops and running sheds:
 - (i) Where electric traction is not likely to be used 5030mm
 - (ii) Where electric traction is likely to be used 6250mm
 - 6 Minimum height above rail level of doorways for a width of 1370mm on either side of centre of track in both workshops and running sheds:
 - (i) Where electric traction is not likely to be used 4875mm
 - (ii) Where electric traction is likely to be used 6250mm

Ashpits etc.:

- 7 Average depth for ashpits in station yards, pits in running sheds and carriage examination pits. 760mm

Note: Siting of Ashpits on run through lines, should, if possible, be avoided.

Vimh

Chapter IV(A) - Rolling Stock (Carriage & Wagon)

Wheels & Axles

1	Wheel gauge, or distance apart, for all wheel flanges	Maximum 1602mm Minimum 1599mm
2	(i) Maximum diameter on the tread of new carriage or wagon wheel, measured at 63.5 mm from wheel gauge face	1092mm
	(ii) Minimum diameter on the tread of new carriage or wagon wheel, measured at 63.5mm from wheel gauge face	914mm

Note: Minimum diameter on tread on new wagon wheel measured at 63.5mm from wheel gauge face can be reduced to 840mm subject to speed restriction of 65kmph for axle load of more than 22t & up to 23t and speed restriction of 45kmph for axle load more than 23t & up to 25t on curves sharper than 875m radius on Grade 880 rail (as per IRS-T-12-2009 specifications) loaded wagon subject to limit of maximum wheel flat as 50mm. For other rail grades and wheel diameters separate study will be required. However, there shall be no such restrictions of speed on 1175HT grade rails.

3	Minimum projection for flange of New tyre, measured from tread at 63.5mm from wheel gauge face	28.5mm
4	Maximum projection for flange of worn tyre, measured from tread at 63.5mm from wheel gauge face	35.0mm
5	Maximum thickness of flange of tyre, measured from wheel gauge face at 13mm from outer edge of flange	29.4mm
6	Minimum thickness of flange of tyre, measured from wheel gauge face at 13mm. from outer edge of flange	16mm
7	Minimum width of tyre	127mm
8	Incline of tread	1 in 20

Height of Floors

9	Maximum height above rail level for floor of any unloaded vehicle other than goods vehicle and goods vehicle having side doors for platform loading/ unloading	1345mm
10	Minimum height above rail level for floor of any fully loaded vehicle other than goods vehicle	1200mm
11	Minimum height above rail level for floor of any fully loaded goods vehicle which has side doors for platform loading/ unloading	1145mm

Note: Maximum/Minimum floor height of such goods vehicle which does not have side doors for platform loading/ unloading, should be determined keeping in view the profile of the maximum moving dimension to diagram no. 1D particularly with respect to width of wagon at various heights.

Buffers & Couplings

12	Distance apart for centers of buffers	1956mm
13	Maximum height above rail level for centres of buffers & CBC couplers for unloaded vehicle	1105mm
14	Minimum height above rail level for centers of buffers & CBC couplers for fully loaded vehicle	1030mm

Note: In case of wagons operated in unitization concept having different coupler heights, the maximum height of coupling line at the outer ends of the Unit shall be as per clause 13 & minimum height of coupling line at the outer ends of the Unit shall be as per clause 14. The minimum height of coupling line at other than outer ends shall not be less than 770mm in fully loaded condition and 845mm in unloaded condition.

Wheel Base & Length of Vehicles

15	Maximum rigid wheel base for four wheeled vehicles	6100mm
16	Minimum distance apart of bogie centres for bogie vehicles	5400mm
17	Maximum distance apart of bogie centres for bogie vehicles	14900mm
18	(i) Minimum rigid wheel base for bogie truck of any vehicle	1830mm
	(ii) Minimum rigid wheel base for bogie truck of passenger vehicle	2440mm
19	Maximum length of body or roof for:	
	(a) 4- wheeled vehicle	8540mm
	(b) Bogie vehicles	21340mm

Note:

- (i) Maximum length of body or roof of bogie vehicles can be upto 23540 mm, subject to tapering of the ends in a manner that the end throw, when calculated as per Appendix, is same as that for ICF coach of 21340 mm length and within this Schedule of Dimensions.
- (ii) A cornice may project beyond the maximum permissible length of the roof up to 51mm in the case of(a) above, beyond each end of the vehicle.
- (iii) Fittings on the end of a vehicle, such as step iron, vacuum brake piping, electrical connections, vestibule etc., need not be kept within the prescribed maximum permissible lengths for bodies of vehicles, but may project beyond the end of the body to a reasonable extent.

20 Maximum length over centre buffer couplers or side buffers:

Vimh

- | | | | |
|--|-----|---------------------|---------|
| | (a) | 4 – wheeled vehicle | 9810mm |
| | (b) | Bogie vehicles | 22300mm |

Note: Maximum length over the centre buffer couplers or side buffers can be increased up to 24000mm for Bogie Vehicles, in accordance to maximum length of body or roof. However, the maximum length over the centre buffer couplers or side buffers for longer coaches shall be so arranged that difference between length over side buffers and length of body or roof is not less than 460mm.

- | | | | |
|----|---|--|---------|
| 21 | Maximum distance apart between any two adjacent axles | | 12345mm |
|----|---|--|---------|

Maximum Moving Dimensions (See diagram 1D)

- | | | | |
|----|---|--|---------------------------------------|
| 22 | Maximum width over all projections at 102mm above rail level, when fully loaded | | 2440mm |
| 23 | Maximum width over all projections, at 305mm above rail level, when fully loaded | | 3050mm |
| 24 | Maximum width over all projections from 305mm above rail level, to 940mm above rail level, when fully loaded | | 3050mm |
| 25 | Maximum width over all projection from 940mm above rail level to 1082mm above rail level, when fully loaded | | 3050mm increasing gradually to 3150mm |
| 26 | Maximum width over all projection from 1082mm above rail level, to 1170mm above rail level, when fully loaded | | 3150mm increasing gradually to 3250mm |

Note: For freight bogie vehicles with maximum length of body or roof upto 14500mm and bogie centre distance upto 10000mm, maximum width overall projections from 305mm above rail level to 1060mm above rail level, when fully loaded, can be relaxed to 3135mm instead of 3050mm.

- | | | | |
|----|---|--|--------|
| 27 | Maximum width over all projections from 1170mm above rail level, when fully loaded to a height of 3735mm when empty | | 3250mm |
|----|---|--|--------|
- (i) Guttering, side lamps and destination boards may project 76 mm on each side beyond the dimensions given above from a height of 2895 mm to 3355 mm above rail level, upto a maximum over all width of 3402 mm.
 - (ii) Coach number plates may project 25mm on each side beyond the dimension given above from a height of 2590 mm to 2895mm above rail level, upto a maximum over all width of 3300mm.
 - (iii) Reservation card holders may project 25mm on each side beyond the dimensions given above from a height of 1750 mm to 1980 mm above rail level upto a maximum over all width of 3300 mm.
 - (iv) The doors are to be either sliding or opening inwards. Handbolts, door locks, handles and window bars shall not, however, project beyond the dimensions given against item above.

Vimk

28 Maximum width over open doors, including all projections for passenger vehicles 4040mm

29 Maximum width over open doors, including all projections for goods vehicles 4265mm

Note: Doors of horse boxes, brake vans, luggage vans and rising and falling flap doors of goods wagons are exempted from this rule.

30 Maximum height above rail level for a width of 1015mm on either side of the centre of unloaded vehicles 4265mm

31 Maximum height above rail level at sides of unloaded vehicles 3735mm

Note :

i) Destination boards for passenger vehicles may project 76 mm above the dimensions upto a maximum height above rail level at sides of vehicles when empty.

ii) (Applicable for clause 27, 28 & 31)

In case of stocks exceeding the 1929 profile and within the maximum moving dimensions shown in diagram 1D, clearance of the following railway is required to be obtained for the following locations before permitting the stock for the general adoption:

S.No.	Railway	Section	Location
1	2	3	4
1.	E.Railway	Andal-Sainthia Chord	Br.No.66
2.	N.F.Railway	Old Malda -Singhabad	Tangon Br.
3.	S.E.Railway	Tata-Rourkela	Up Saranda Tunnel
4.	S.E.C.Railway	Bilaspur-Katni	DnBhortonk Tunnel

32 Minimum height above rail level when fully loaded for a width of 1220mm on either side of centre of track with the exception of wheels and attachments thereto (vide note below) 91mm

Note: A tyre or an attachment of a wheel may project below the minimum height of 91 mm from a distance of 51 mm inside to 216 mm outside of the gauge face of the wheel.

33 Minimum height above rail level, when fully loaded at 1525 mm 305mm

from centre of track

Loading Gauge for Goods

34	Maximum width	3250mm
35	Maximum height above rail level at center	4265mm
36	Maximum height above rail level at sides	3735mm

Note: The loading gauge is for testing loaded and empty vehicles; the maximum moving dimensions are given in items 27, 28, 30 and 31 above.

Viank

CHAPTER IV (B)
Rolling stock, 3660 mm wide stock

Note :

These dimensions shall not be adopted in designs for rolling stock without the special sanction of the Railway Board in each case.

Maximum future moving dimensions:

(See diagram No. 1-A)

1 Maximum width over all projections:

(i)	At 102mm above rail level, when fully loaded	2895mm
(ii)	At 305mm above rail level, when fully loaded	3505mm
(iii)	From 305mm above rail level to 1145mm above rail level when fully loaded	3505mm
(iv)	From 1145mm above rail level, when fully loaded to a height of 3355mm when empty	3660mm
(v)	At 4265mm above rail level, when empty	3505mm

2 Maximum width over open doors, including all projections, for passenger vehicles 4495mm

3 Maximum width over open doors, including all projections, for goods vehicles 4500mm

Note: Doors of horse boxes, brake vans, luggage vans and rising and falling flap doors of goods wagons are exempted from this rule.

4 Maximum height above rail level for a width of 915mm on either side of the centre of unloaded vehicles 4725mm

5 Maximum height above rail level at sides of unloaded vehicles 4265mm

6 Minimum height above rail level, when fully loaded for a width of 1450mm on either side of centre of track, with the exception of wheels and attachments thereto (vide note below) 102mm

Note: A tyre or an attachment to a wheel may project below the minimum height of 102mm from a distance of 51mm inside to 216mm outside of the gauge face of the wheel.

7 Minimum height above rail level, when fully loaded at 1755mm from centre of track 305mm

Loading gauge for goods:

8 (i) Maximum width at a height of 3380mm above rail level 3710mm

(ii) Maximum width at a height of 4295mm above rail level 3555mm

9 Maximum height above rail level for a width of 915mm on either side of the centre of track 4750mm

10 Maximum height above rail level at sides 4295mm

Note: The loading gauge is for testing loaded and empty vehicles, the maximum moving dimensions are given in items 1(iv), 4 and 5 above.

Vinuk

Chapter IV (C) Rolling Stock (Locomotive)

Wheel and axles:

1	Wheel gauge or distance apart for wheel flanges:		
	(a) Wheels with thick flanges/wear adopted wheel profile	1596mm	
	(b) Wheels with standard flanges	1600mm	
	(c) Wheels with thin flanges	1600mm	
	(d) Wheels without flanges	1600mm	
	(See item 6.5 for identification of thick/wear adopted, standard & thin flanges)		
2	(i) Maximum diameter on the tread of new locomotive carrying wheels measured at 63.5mm from wheel gauge face	1250mm	
	(ii) Minimum diameter on the tread of new locomotive carrying wheels measured at 63.5mm from wheel gauge face.	914mm	
3	Minimum projection for flange of new tyre measured from tread at 63.5mm from wheel gauge face	28.5mm	
4	Maximum projection for flange of worn tyre measured from tread at 63.5mm from wheel gauge face	35mm	
5	Maximum and minimum thicknesses of tyre flanges measured at 13mm from outer edge of flange:		
		Max.	Min.
	(a) Thick flanges/wear adopted wheel profile	32mm	-
	(b) Standard flanges	28mm	-
	(c) Thin flanges	18mm	-

Note:

- (i) The above values of flange thicknesses are measured from the back face of the tyre.
- (ii) Minimum size of flange of locomotive tyres shall be determined by condemning profile gauge which specifies the minimum thickness and the limits of angularity of the flange on the gauge face.

6	Minimum width of tyres:		
	(a) Locomotive coupled wheels	133mm	
	(b) Locomotive wheels other than coupled	127mm	
7	Incline of tread	1 in 20 for all profiles except wear adopted profile for which the tread inclination of 1 in 20 will merge with radii of the wear adopted profile	

Vimke

Buffers & Couplings:

8	Distance apart for centres of buffers	1956mm
9	Maximum height above rail level for centres of buffers & CBC for empty locomotive	1105mm
10	Minimum height above rail level for centres of buffers & CBC when fully loaded	1030mm

Maximum Moving Dimensions:

(see New Diagrams 1D)

11.	Maximum length of body or roof	21340mm
-----	--------------------------------	---------

Note: Maximum length of body or roof can be upto 23540mm, subject to tapering of the ends in a manner that the end-throw, when calculated as per Appendix, is same as that for ICF coach of 21340mm length and within this Schedule of Dimensions.

12	Maximum length over centre buffer couplers or side buffers	22300mm
----	--	---------

Note: Maximum length over the centre buffer couplers or side buffers can be increased upto 24000mm for Bogie Vehicles, in accordance to maximum length of body or roof. However, length over the centre buffer couplers or side buffers be so arranged that difference between length over side buffers and length of body or roof is not less than 460mm.

13. Maximum width over all projections:

(i)	At 91mm above rail level, when fully loaded	2440mm
(ii)	At 91mm to 305mm above rail level, when fully loaded	2440mm increasing gradually to 3050mm
(iii)	From 305mm above rail level, to 940mm above rail level, when fully loaded	3050mm
(iv)	From 940mm above rail level, to 1082mm above rail level, when fully loaded	3050mm increasing gradually to 3150mm
(v)	From 1082mm above rail level, to 1170mm above rail level, when fully loaded	3150mm increasing gradually to 3250mm
(vi)	From 1170mm above rail level, when fully loaded to a height of 3735mm above rail level, when empty	3250mm

Note: (i) Maximum width over all projections from 925mm (minimum in all conditions) above rail level to 1082mm above rail level, when fully loaded can be 3075mm (in the bogie portion only).
(ii) Maximum distance apart of bogie centres (i.e. pivot centres) for locomotives shall be 15810mm, subject to the condition that width of locomotive at the centre is such that mid-throw, when calculated as per Appendix, is same as that for ICF coach of 21340mm length and within this Schedule of Dimensions.

14	Maximum height above rail level for a width of 1015mm on either side of The centre of unloaded vehicle	4265mm
----	--	--------



15 Maximum height above rail level at sides of empty locomotives 3735mm

Maximum Moving Dimensions for X-Class locomotives

16 Maximum width overall projections

(i) At 102mm above rail level, when fully loaded 2440mm

(ii) From 305 mm above rail level to 1110 mm above rail level, when fully loaded 3135mm

(iii) From 1110mm above rail level to a height of 1145mm above rail level, when fully loaded 3135mm increasing gradually to 3200mm

(iv) From 1145 mm above rail level when fully loaded to a height of 3735 mm above rail level, when empty 3200mm

17 Maximum height above rail level for width of 305 mm on either side of centre of empty locomotives 4470mm

Note: The dimension given in item no. 17 shall not be adopted without obtaining prior approval of Railway Board.

18 Maximum height above rail level at sides of empty locomotives 3735mm

19 Minimum height above rail level when fully loaded for a width of 1220 mm on either side of centre of track with the exception of wheels and attachments thereto (vide note below) 91mm

Note: A tyre or an attachment to a wheel or sand pipes in line with the wheel may project below the minimum height of 91mm from a distance of 51mm inside to 216 mm outside of the gauge face of the wheel.

20 Min. height above rail level when fully loaded at 1525 mm from centre of track 305mm

Vimik

CHAPTER V - ELECTRIC TRACTION (Direct Current)

Note: Wherever electric traction, employing overhead conductor wires, is in use strict orders must be issued prohibiting any one from getting on the roofs of vehicles until the current in the overhead conductors has been switched off and the conductors themselves have been earthed.

1	Minimum height from rail level to the underside of live conductor wire:-	
(i)	Under bridges and tunnels	5030mm
(ii)	In the open	5335mm
(iii)	In running and carriage sheds	5790mm
(iv)	At level crossing	5485mm

Note: The height prescribed in item 1(iv) applies also to tramway trolley wires crossing the railway.

2	Maximum height from rail level to the underside of live contact wire except in running and carriage sheds	5790mm
---	---	--------

Note: In the case of running and carriage sheds, the maximum height of the contact wire will be determined in each case based on the operating range of the pantograph and the permissible electrical clearances required inside the sheds.

3	Maximum variation of live conductor wire on either side of the central line of track	
(i)	On straight track	230mm
(ii)	On curves (on the inside of the curve)	380mm
4	Minimum distance between live conductor wire and any structure	130mm
5	Maximum width of pantograph collector	2030mm

Vimh

CHAPTER V (A) Electric Traction

25 kV A.C. 50 Cycles

Note: Wherever electric traction is in use, special precautions shall be taken in accordance with provisions made in chapter XVII of 'General Rules' for all Open lines of Railways.

Electrical clearances:

1 Vertical and lateral distance between 25 kV live parts and earthed parts of fixed structures or moving loads/rolling stocks shall be as large as possible. The minimum vertical and lateral electrical clearances to be maintained under worst condition of temperature, wind etc. between any live part of the overhead equipment or pantograph and parts of any fixed structures (earthed or otherwise) or moving loads/rolling stocks shall be as under :

(i)	Long duration	250mm
(ii)	Short duration	200mm

Note: (a) Long Duration means when the conductor is at rest and short duration means when the conductor is not at rest.

(b) A minimum vertical distance of 270 mm shall normally be provided between rolling stock and contact wire to allow for a 20 mm temporary raising of the track during maintenance. Wherever the allowance required for track maintenance exceed 20 mm, the vertical distance between rolling stock and contact wire shall correspondingly be increased.

(c) Where adoption of above clearances is either not feasible or involves abnormally high cost, Permanent Bench Mark shall be provided to indicate the level of track to be maintained.

2 Minimum height from rail level to the underside of contact wire :

(i)	Under Bridges and in Tunnels	4.80 metre
(ii)	In the open	5.50 metre
(iii)	At level crossings	5.50 metre
(iv)	In Running and Carriage Sheds	5.80 metre

Note

(a) In cases where it is proposed to allow Locomotives or Rolling stocks not higher than 4.42 m, the minimum height of Contact Wire, specified under item 2(i) above may be reduced to 4.69 metre.

(b) In cases, where it is proposed to allow only Locomotive or Rolling Stocks not higher than 4.27m the minimum height of contact wire, specified under Item 2(i) above may be reduced to 4.54m. A board showing this restriction and specifying "locomotives or Stocks not permitted to ply on such section" shall be exhibited at the entrance to the same.

(c) For movement of Over Dimensional consignments, the height specified under Item 2(i) above shall be increased by the difference between the height of the consignment contemplated and 4.42m. In case, such an over dimensional consignment is moved at speed not exceeding 15Km/h and is also

Vink

specially escorted by authorized Railway Staff, the derived height of Contact Wire may be reduced by 50 mm.

- (d) On curves, all vertical distances specified in Item (2) above, shall be measured above the level of the inner rail, increased by half the super-elevation.
- (e) Suitable prescribed gradient on the height of contact wire shall be provided for connecting these wires installed at different heights.

3 Maximum variation in alignment of the live Conductor Wire on either side of the centre line of track under static condition:

(i)	On straight track	200 mm
(ii)	On curves	300 mm

Note: These limits would not apply to special locations e.g. Insulated Overlaps and Out of Run Wires.

4	(i)	Maximum width of pantograph collector	2030mm
	(ii)	When DC traction is converted to 25 kV AC traction, width of Pantograph collector {subject to it being within the approved MMD}	: 2030mm

Note: A tolerance of plus 10 mm on maximum width specified is permissible to accommodate variation in manufacture and mounting with respect to the centre line of vehicle.

5 In the case of light structures such as foot-over bridges, it would be desirable to keep a standard height of contact wire of 5.50m. In case of heavy structures, such as flyover bridges or Road over bridges, it is desirable to keep the height of contact wire as low as possible, consistent with the requirements of movement of Standard Class 'C' Over-Dimensional Consignments of height 4.80m.

Vimh

CHAPTER V-B - 25 kV A.C. Electric Traction with High Rise OHE

Note: Provisions under this chapter are applicable only for electrification of routes where double stack container having maximum height of 6809 mm is plying.

1. Minimum Height from rail level to the underside of contact wire in open: 7520mm

Note: On curves, the height shall be measured from the higher or super elevated rail.

2. Minimum Height of Overhead structure above rail level for a distance of 1600 mm on either side of the centre of track shall be as under:

(A) Light Overhead Structures, such as Foot Over Bridges: 8430mm

(B) Heavy Overhead Structures, such as Road Over Bridges and Flyovers: 8050mm

(C) Heavy Overhead Structures, such as Road Over Bridges and Flyovers, if any turnout or crossover is located under that heavy overhead structure or within 40 meters from its nearest face: 8430mm

Note:

(i) Necessary provision shall be made in overhead structure and overhead equipment to permit an extra allowance for raising of track in future to cater for modern track structure in the form of increased ballast cushion of 350 mm, larger sleeper depth of 230 mm and heavier rail sections of 200 mm including 10 mm thick rubber pad by using longer traction overhead equipment masts, if necessary.

(ii) In case of restricted height of existing overhead structures, minimum height of overhead structure for a distance of 1600mm on either side of the centre of track for provision of high rise OHE as per note (iii) below, to permit operation of double stack container having maximum height as 6809 mm shall be as under:

(a) Light Overhead Structures, such as Foot Over Bridges: 7568mm

(b) Heavy Overhead Structures, such as Road Over Bridges and Flyovers: 7468mm

(c) Heavy Overhead Structures, such as Road Over Bridges and Flyovers, if any turnout or crossover is located under that heavy overhead structure or within 40 m from its nearest face: 7568mm

For these minimum restricted heights, catenary wire shall be terminated outside overhead structure (Road Over Bridges & Flyovers / Foot Over Bridges).



(iii) In case of restricted height of existing overhead structures, bridges and tunnels as mentioned in (ii) above, the minimum height of underside of the contact wire from rail level can be reduced to 7166 mm. In such cases, a special study shall be made, before 25 kV AC traction is introduced as explained below:

(a) Height of the rolling stock:	6809mm
(b) Short duration electrical clearance:	200mm
(c) Additional electrical clearance for oscillation of the contact wire (For OHE span length of 49.5m or below):	50mm
(d) Allowance for track upgradation/maintenance:	50mm
(e) Rise in rolling stock height under dynamic conditions:	57mm
(f) Minimum height of contact wire:	7166mm

(iv) Extra vertical clearance shall be provided on curves as under:

$$\text{Extra vertical clearance (mm)} = \frac{\text{Width of MMD (mm)} \times \text{Super elevation (mm)}}{\text{Dynamic gauge (mm)}}$$

This extra vertical clearance on curve would be with respect to inner rail of curve.

3. Clearance for Power Line Crossings Including Telephone Line Crossings of Railway Tracks:

SL	Over Head Crossing Voltage	Minimum Clearances From Rail Level		Minimum Clearance Between Highest Traction Conductor and Lowest Transmission Line Crossing Conductor
		Existing Power Line Crossing For Non-Electrified Territory	New Power Line Crossing or Crossing Planned For Alteration	
(1)	(2)	(3)	(4)	(5)
(a)	Upto and including 11kV	Normally By Underground Cable		
(b)	Above 11kV & upto 33kV	10860mm	16660mm	2440mm
(c)	Above 33kV & upto 66kV	11160mm	16960mm	2440mm
(d)	Above 66kV & upto 132kV	11760mm	17560mm	3050mm
(e)	Above 132kV & upto 220kV	12660mm	18460mm	4580mm
(f)	Above 220kV & upto 400kV	14460mm	20260mm	5490mm
(g)	Above 400kV & upto 500kV	15360mm	21160mm	7940mm
(h)	Above 500kV & upto 800kV	18060mm	23860mm	7940mm

Note:

(i) All height/clearances are in mm and under maximum sag conditions.

Vimh

(ii) If the crossing is provided with a guarding, a minimum clearance of 2000mm shall be maintained between bottom of the guard wire and highest traction conductor.

(iii) Power line crossing in yards & stations area shall be avoided.

(iv) For any electrification work of existing line; doubling/gauge conversion along with electrification, existing crossings can continue, if dimensions are as per Column (5) above, even if dimensions of Col (3) are not satisfied i.e. for electrification works Col (3) is not applicable.

4. Maximum width of Pantograph Collector:

2030 mm

Note: A tolerance of plus 10mm on maximum width specified is permissible to accommodate variation in manufacture and mounting with respect to centre line of vehicle.

SCHEDULE - II

Existing infringements of schedule I which may be permitted to continue on existing 1676 mm gauge Railways.

The following infringements of the dimensions prescribed in schedule I may, subject to such restrictions of speed as are considered necessary, be permitted on existing railways (see diagram No. 3) it being understood that when structures are altered they will be rebuilt to comply with schedule I, except in case of structures falling under item 7.

Dimensions marked (a) refer to the requirements for 3250 mm wide stock [chapter IV(A) of schedule I], and those marked (b) refer to the requirements for 3660 mm wide and 4725 mm high stock (chapter IV(B) of Schedule I)

1.	(a)	Minimum distance centre to centre of tracks	3660mm
	(b)	Minimum distance centre to centre of tracks	4040mm
2.	(a)	Minimum clear horizontal distance from centre of track to any fixed structure from rail level to 1065mm above rail level	1675mm
	(b)	Minimum clear horizontal distance from centre of track to any fixed structure from rail level to 1065mm above rail level	1905mm
3.	(a)	Minimum clear horizontal distance from centre of track to any fixed structure from 1065mm above rail level to 3505mm above rail level	1980mm
	(b)	Minimum clear horizontal distance from centre of track to any fixed structure from 1065mm above rail level to 3355mm above rail level	2135mm
4.	(a)	Minimum clear horizontal distance from centre of track at 4265mm above rail level	2055mm
5.	(a)	Minimum clear height above rail level for a distance of 305mm on either side of centre of track.	4420mm
	(b)	Minimum clear height above rail level for a distance of 915mm on either side of centre of track.	5030mm

Note:

- i) Items 2(a), 3(a), 3(b) and 4(a) refer to structures outside station yards only.
- ii) Where speed is restricted to 16 km/h, the minimum clear horizontal distance under 4(a) may be reduced to 1980 mm.
- iii) Where, as on girder bridges, ashpits, etc., the structure is not likely to be out of plumb and the super-elevation (or level of rails) does not vary and where the speed is restricted to 16 km/h, the above dimensions may be reduced to:
3580 mm for 1(a), 3960 mm for 1(b),
1905 mm for 3(a), 2055 mm for 3(b),
1980 mm for 4(a),
4265mm for 5(a), 4875 mm for 5(b)

Vimh

(iv) To the horizontal distance given in 1 to 5 must be added the extra allowance for curves (See Appendix). Where existing structures do not permit of these allowances being given, they may be reduced by limiting the superelevation to be allowed for outer over inner rail. When this is done a notice board should be erected against the structure, stating the maximum permissible superelevation.

6. The minimum permissible clearances in existing tunnels and girder bridges shall be:

i) Under any circumstances and subject to any restriction of speed which it may be considered necessary to impose:

	In tunnels (See Diagram No.3)	On girder bridges
At 'A'	229mm	229mm at top of sides of vehicles
'B'	305mm	229mm at side of vehicles
'C'	380mm	305mm between moving trains
'D'	229mm	152mm above vehicles

ii) For unrestricted speeds:

	In tunnels	On Girder Bridges
At 'A'	380mm	229mm at top of sides of vehicles
'B'	535mm	455mm at sides of vehicles
'C'	610mm	535mm between moving trains
'D'	305mm	229mm above vehicles.

Where doors opening inwards or of the recessed or sliding type are provided the minimum clearances in tunnels and bridges may be reduced to 380 mm, at 'B' and 455 mm at 'C' for unrestricted speed. To the above must be added the extra allowance for curves (See Appendix).

7. Structures which have already been built in accordance with items 10 and 13 of chapter I, items 9,10 and 11 of chapter II and items 5 and 6 of chapter III of Schedule I as contained in the 1958 reprint, reproduced in note below, may infringe the dimensions now shown against these items. Such infringements may continue and alterations for the removal of such infringements need be taken up only when 25 K.V. A.C. Electric Traction is undertaken when a study shall be made of each structure to limit the extent of alterations as indicated in Appendix A to chapter V-A.

Note: The item referred to 7 above as reproduce below are not minimum. The minimum dimension in Schedule-II are as per items 1 to 6, 8 and 9.

Item 10 chapter I, Schedule I

Minimum height above rail level for a distance of 915 mm on either side of the centre of track for overhead structure

4875mm

Vink

Note: See Appendix for 'extra clearance required on curves'

Item 13, Chapter I Schedule I

(i) Minimum distance centre to centre of tracks 4725mm

Note: When respacing existing lines, the minimum distance centre to centre of tracks may be reduced from 4725 mm to not less than 4495 mm for the purpose of avoiding heavy alterations to tunnels or through or semi through girder bridges. The 4725 mm dimension is to be adopted for all new works.

(ii) Minimum horizontal distance from centre of track to any structure shall be as follows:

Height above rail level	Horizontal distance from centre of track
a) From 0 to 305 mm	1905 mm
b) From 305mm to 1065mm	1905 mm increasing to 2360mm
c) From 1065mm to 3355mm	2360 mm
d) From 3355mm to 4420mm	2360 mm decreasing to 2135mm
e) From 4420mm to 5410mm	2135 mm decreasing to 915mm

Note:

- a) Where electric traction is not likely to be used overhead bracing of bridges may be 5030 mm above rail level for a distance of 1370mm on either side of centre of track.
- b) See Appendix for extra clearance required on curves.

Item 9, chapter II, schedule. I

Minimum height above rail level for a width of 1370mm on either side of the centre of track, of tie rods or any continuous covering in a passenger station. 6100mm

Note: Item 9 does not apply to overhead piping parallel to the track.

Item 10, Chapter II, Schedule I

Minimum height above rail level for a width of 1370mm on either side of the centre of track of a signal gantry or a foot over bridge in passenger station 4875mm

Note:

- (a) This also applies to overhead piping arrangements parallel to track wherever provided which shall necessarily be changed over to the ground hydrants when the section is electrified.

Item 11, chapter II, Schedule I

Minimum horizontal distance from centre of track to any structure

- (i) From rail level to 305mm above rail level 1675mm
- (ii) From 305mm above rail level to 3355mm above rail level 2135mm
- (iii) From 3355mm above rail level to 4115mm above rail level 2135mm decreasing

Vishakh

- | | | |
|------|---|---------------------|
| (iv) | From 4115mm above rail level to 6100mm above rail level | to 1980mm
1370mm |
|------|---|---------------------|

Note: See Appendix for clearance required on curves.

Item 5, Chapter III, Schedule I

Minimum height above rail level to overhead tie bars, girders etc in workshops and running sheds

- | | | |
|------|--|--------|
| (i) | Where electric traction is not likely to be used | 5030mm |
| (ii) | Where electric traction is likely to be used | 6176mm |

Item 6, Chapter III, Schedule I

Minimum height above rail level of doorways for a width of 1370mm on either side of centre of track, in both workshops and running sheds

- | | | |
|------|--|--------|
| (i) | Where electric traction is not likely to be used | 4875mm |
| (ii) | Where electric traction is likely to be used | 6176mm |

A.C Traction 25 K.V. 50 cycles

8. General: For tunnels & through girder bridges.

Minimum horizontal distance from centre of track to any structure from 4420mm to 5410 mm above rail level	2135mm decreasing to 915mm
---	----------------------------

Note: See Appendix for extra clearance required on curves.

- | | |
|---|--------|
| 9. Minimum horizontal distance from centre of track to any structure from 4115 mm to 6100 mm above rail level | 1370mm |
|---|--------|

Note: See Appendix for extra clearance required on curves.

Vink

APPENDIX

Note:

- a) Column 5 applies to goods platforms 1065 mm above rail level which are not on a running line. For such platforms on running lines 25mm should be added to the figures given in column 5.
- b) Where electric traction is likely to be used, add 1mm for every 12mm of height above 5410 to the figures given in the column 7 upto the height at which the conductor wires are likely to be fixed.
- c) Where there is a structure between tracks, the extra clearance to be provided must be according to columns 5, 6, 7 and 8 instead of column 9.
- d) Appendix showing extra clearance on curves has been revised. In the revised table, the maximum permissible speed and corresponding superelevation are indicated and the required clearances based on these superelevations have been given.

Note on Extra Clearance on Curves

1. It has been contended that the extra clearance prescribed for curves both in the 1913 and in the 1922 Schedule of Dimensions was too liberal in the case of platforms, and caused a gap between the platform and foot board at certain parts of a bogie carriage, which was dangerous to passengers. In the 1922 schedule, the allowance for lurching and sway of the carriage was treated as entirely additional to that already provided for such motion in the clearance given for straight platforms whereas only additional sway due to the curved track in excess of the maximum occurring on straight track need be provided for. The amount of superelevation allowed for was also excessive on the sharper curves.
2. The clearance provided between a vehicle (i.e. the foot boards) and the platform coping on the straight is 152mm. It is considered that to reduce the average distance between a curved platform and the foot boards the minimum clearance between a platform on the outside of a curve and the ends of a vehicle may safely be reduced to 127mm. The maximum movement due to lurching at the centre of a vehicle cannot be greater than seven tenths of that at the ends, so that the minimum clearance between the centre of a vehicle and a platform on the inside of a curve may be safely reduced to 102mm. Therefore, in calculating the extra allowance to be provided on curves as explained in paragraph 5,6,7 and 8, a reduction of these extra allowance has been made of 51mm on the inside and 25mm on the outside of curve as shown in paragraph 7.
3. Allowance to be made:- The additional clearance to be given on the inside of a curve must include the effect of curvature, the lean due to superelevation, and an allowance for any additional sway of the vehicles over that already provided for in the clearance on straight tracks. The additional clearance to be given on the outside of a curve must allow for the effect of curvature. Additional sway or lurch due to curve can be considered as fully counteracted by the inward lean of the vehicle due to superelevation.
4. Allowance for curvature: The allowance for curvature for a vehicle 21340mm long, 14785mm between bogie centre shall be calculated as under:-

At the centre of vehicle

Vionh

$$V = \frac{14.785 \times 14.785 \times 1000}{8R} = \frac{27330}{R} \text{ mm}$$

At the end of vehicle

$$V_o = \frac{21.340 \times 21.340 \times 1000}{8R} - \frac{27330}{R} = \frac{29600}{R} \text{ mm}$$

Where R is the radius of the curve in metres.

5. Allowance for superelevation: The lean due to superelevation at any point at height 'h' above rail level is given by :

$$L = \frac{h}{g} \times S \quad \text{where S is the superelevation, g is the gauge of the track.}$$

6. Allowance for additional sway on curves: The provision for additional lurch and sway on the inside of a curve as given in the 1913 and 1922 schedules has been adopted, namely one-fourth of the lean due to superelevation. No provision has been made for additional sway due to a curve in the outward direction for reasons already given in paragraph 3 above.

7. Platforms:- For platforms the total additional clearance to be provided is:
On the inside of a curve

$$(i) \quad V + \frac{5}{4} L - 51 \text{ mm}$$

Where L is the lean in millimetres.

On the outside of a curve--

$$(ii) \quad V_o - 25 \text{ mm.}$$

(see paragraph 2 above)

Column 5 of the Appendix has been calculated for a high passenger platform 840mm according to formula(i).

8. Clearance from adjacent structure on the inside of a curve:--For obtaining the figures given in columns 6 & 7, formula(i) of paragraph 7 above has been used.

9. Clearance from adjacent structures on the outside of a curve: For column 8, formula (ii) of paragraph 7 above has been used.

10. Extra clearance between adjacent tracks: The worst case will be when the end of a bogie carriage on the inner track is opposite the centre of a similar carriage on the outer track. Nothing is allowed for superelevation, it being assumed that both tracks will be inclined the same amount. Though there are cases where a different superelevation is provided on each track, the distance allowed between centres of tracks gives a sufficient margin of safety to permit of this being omitted from consideration. The formula used for column 9 is

$$V + V_o + \frac{2L}{4}$$

and as the height adopted for the value of h in calculating L, is 3355mm, the above therefore reduces to

$$V + V_o + S$$

Vinik

11. Railway Board vide letter No. 68/WDO/SC/1 dt. 16.4.1968 has issued instructions for increase of speed over curves for contemplating 160/200 kmph speed on Broad Gauge. As stated therein, while locating any permanent structures by the side of the track in the case of trunk routes and main lines which have the potential for the increase of speed in future, the need for additional clearances for realignment of curves for higher speed operation should be kept in view. The particulars of the extra clearances necessary on curves between structures and the adjacent track and between tracks when there are no structures are given in additional appendix for extra clearances on curves for maximum speed of 200 kmph. The same should be followed when high speeds of the order of 160/200 kmph are contemplated.
Extra clearances for the speeds specified above are shown in Annexure-I & II.
12. The clearances worked out (Annexure I & II) are for a vehicle 21340 mm long with bogie centres 14785 mm apart. For vehicles having different dimensions, the clearances can be worked out in the similar manner.

ADDITIONAL APPENDIX ---- EXTRA CLEARANCES

EXTRA CLEARANCES ON CURVES FOR HIGH SPEED ROUTES (160 KMPH)

Degree of curvature	Radius of curve	Maximum permissible speed	Superelevation	Extra Clearance between structure and adjacent track			Extra clearance between adjacent track when there is no structure between track	
				Upto 840 mm above rail level	From 840 mm to 4420 mm above rail level	At 5410 mm above rail level*		
1	2	3	4	5	6	7	8	9
Degree	Meter	Kmph	mm	mm	mm	mm	mm	mm
1	1750	158	95	25	280	350	-	130
1.5	1167	145	142	60	440	545	-	190
2	875	130	164	85	520	640	10	230
3	583	106	165	100	540	665	25	265
4	438	92	165	115	555	680	45	295
5	350	83	165	130	570	695	60	300
6	292	75	165	145	590	710	75	360
7	250	70	165	165	605	725	95	395
8	219	65	165	180	620	740	110	425
9	194	62	165	195	635	755	130	460
10	175	58	165	210	650	770	145	490

- Note- (i) For intermediate heights between 4420mm and 5410mm add 1mm for every 12mm of height to the figures given in column 6.
(ii) Maximum permissible speed has been work out for cant deficiency value of 100mm.

ADDITIONAL APPENDIX ---- EXTRA CLEARANCES

EXTRA CLEARANCES ON CURVES FOR MAXIMUM SPEED OF 200 KMPH

Degree of curvature	Radius of curve	Maximum permissible speed	Super-elevation	Extra Clearance between structure and adjacent track				Extra clearance between adjacent track when there is no structure between track
				Inside of curve			Outside of curve any ht	
				Upto 840 mm above rail level	From 840 mm to 4420 mm above rail level	At 5410 mm above rail level		
1	2	3	4	5	6	7	8	9
Degree	Meter	Kmph	mm	mm	mm	mm	mm	mm
1	1750	190	185	81	574	711	-	218
1.5	1167	155	185	88	582	719	-	234
2	875	134	185	96	590	727	9	250
3	583	110	185	112	606	742	26	283
4	438	95	185	127	621	758	43	315
5	350	85	185	143	637	774	60	348
6	292	77	185	159	653	789	76	380

- Note- (i) For intermediate heights between 4420mm and 5410mm add 1mm for every 12mm of height to the figures given in column 6.
(ii) Maximum permissible speed has been work out for cant deficiency value of 100mm.

APPENDIX A TO CHAPTER V-A

Clearances required for 25 K.V., single phase,

A.C. Electric Traction

1. It is desirable to provide the maximum possible clearances in the case of lines equipped for 25kV AC 50 Cycle single phase electric traction.

Minimum Clearances between live bare conductors/ pantographs and Structure –

- (a) Short term clearances - Vertical and lateral distance between live : 200 mm
Conductors and earth (normally existing only for a brief period)
 - (b) Long term clearance - Vertical and lateral distance between live : 250mm
Conductors and earth (which may remain for a considerable period)
-
2. In order to ascertain whether the requisite clearance would be available under an existing structure, the permissible height of the contact wire shall be determined. For this purpose, the following particulars should be known:-
 - (a) Particulars of the structure including profile
 - (b) Allowance for slewing of tracks
 - (c) Allowance for low joints in tracks.
 - (d) Radius of curvature of track under the structure
 - (e) Super-elevation of track under the structure
 - (f) Maximum permissible speed under the structure
 - (g) Maximum dimensions of over-dimensional consignments which are permissible and safety measures which would be taken for movement of over-dimensional consignments.
 - (h) Location of the structure in relation to level crossings, water columns and turnouts in the vicinity.
 - (i) Type of overhead equipment.
 3. After determining permissible height of the contact wire based on above particulars, the clearance required between the lowest portion of the bridge or structure and the top most position of the overhead wire shall be determined in each case after study of the following:
 - a) System of tensioning of the overhead equipment
 - b) Atmospheric conditions.
 - c) Maximum permissible number of electric locomotives per train (double or triple headed)
 - d) Location of the structure in relation to points and crossings, overlap, spans, etc.
 - e) Length of structure along tracks.
 - f) Type of structure, girder, masonry etc.
 - g) The span of overhead equipment under the bridge
 - h) Presence of traction feeder
 - i) Likelihood of diesel locomotives halting under the structure.

Vimk

[Faint, illegible text covering the page, possibly bleed-through from the reverse side. A horizontal line is visible across the middle of the page.]

4. (a) The minimum height of contact wire for a stock height of 4.42m to be able to run on all sections electrified with 25 KV A.C. traction system with live traction overhead equipment :

(i) Height of the locomotive	: 4.42m
(ii) Minimum clearances to contact wire	: 0.25m
(iii) Allowance for track maintenance	: 0.02m
(iv) Minimum height of contact wire (Total)	: 4.69m

Note: For OHE span length of 49.5m or below, the oscillations of contact wire get reduced to 0.05m and the minimum height of contact wire in para 4(a)(iv) can be reduced to 4.69m.

(b) After determining the minimum height of contact wire on the assumption that it would permit passage of standard locomotives and stock, the maximum height of over Dimensional Consignments (ODC) with the live overhead equipment at speed over 15km/h (when vertical oscillation of overhead equipment is pronounced) is derived as under:

Minimum height of Contact Wire	: 4.69m
Less-	
(i) Minimum electrical clearance	: 0.20m
(ii) Track allowance	: 0.02m
(iii) Allowance for vertical oscillation of contact wire under influence of moving pantographs	: 0.05m
Total	: 0.27m

Permissible maximum height of Over Dimensional Consignment : 4.42m.

(c) If an Over Dimensional Consignment is moved at slow speed not exceeding 15 kmph, there will be no downward displacement (due to oscillation) of contact wire. However, to cater for the likelihood of an Over Dimensional Consignment halting under a structure, a clearance of 0.25 m under rest condition is to be provided, vide item 1 of Chapter V - A. In this case the derived height of contact wire may be reduced by 50 mm.

5. In the case of light structures such as foot-over bridges, it would be desirable to keep a standard height of contact wire of 5.50m. In case of heavy structures, such as flyover bridges or road over bridges, it is desirable to keep the height of contact wire as low as possible, consistent with the requirements of movement of Standard Class 'C' Over-Dimensional Consignments of height 4.80m.

V.ink

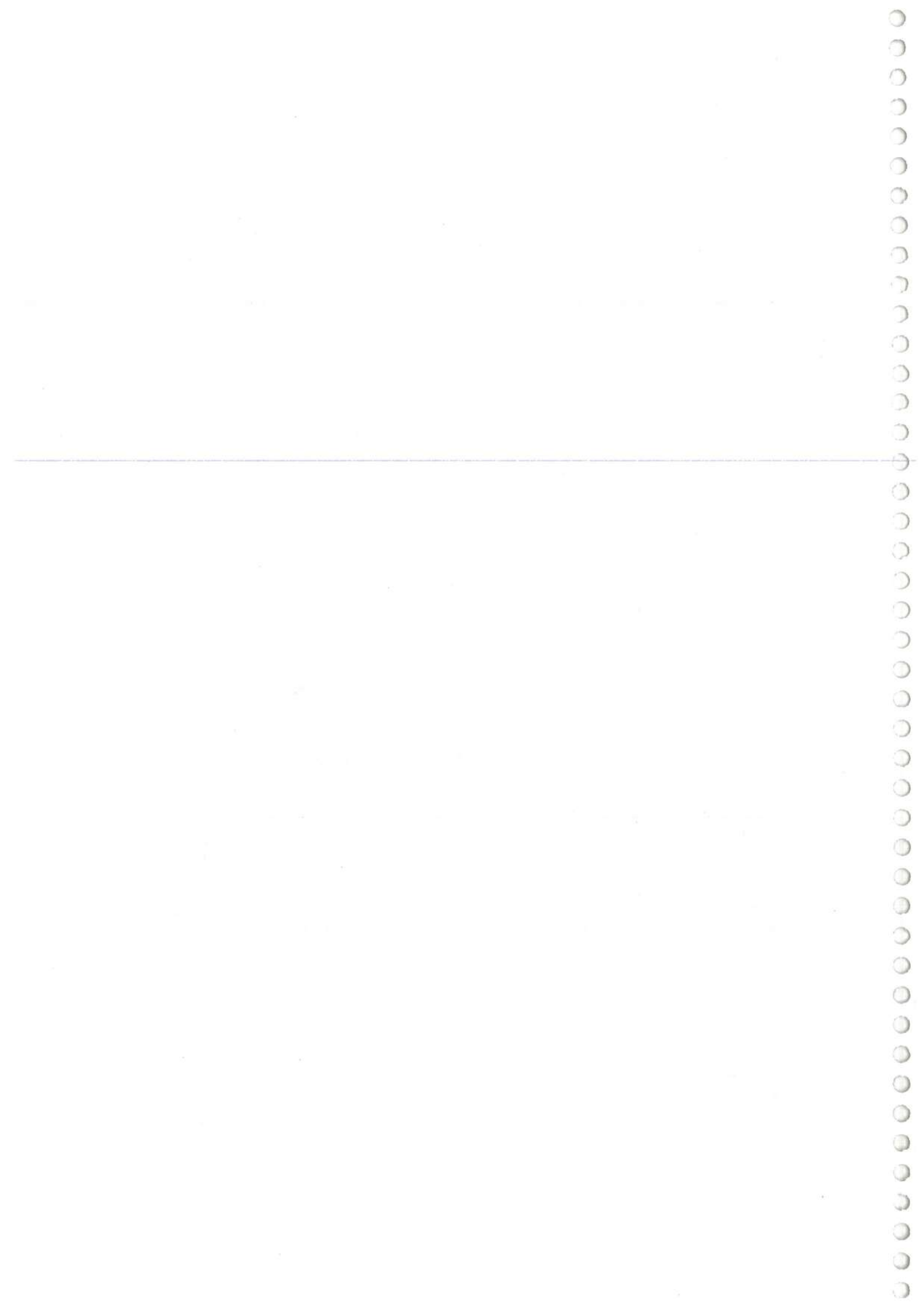

Statement showing the correction slips issued to Indian Railway Schedule of Dimensions (BG), Revised-2004

Correction Slip No.	File No.	Date of issue IRSOD-2004	Page Nos. of
1.	97/CEDO/SR/14	March, 2006	10
2.	97/CEDO/SR/14	March, 2006	10
3.	CT/SD/REV/BG/MG	Sept, 20	3,5,8,9,12,13,14,15,16,19, 21,22,25,31 & 34
4.		Not Issued	
5.	CT/SD/REV/BG/MG	Feb, 2009	11
6.	CT/SD/REV/BG/MG	Oct, 2009	22
7.	2011/CEDO/SD/IRSOD/Elect./02	March, 2012	6, 7, 8, 27, 28, 37, 38, 39
8.	2008/CEDO/SD/09	Nov, 2012	16
9.	2012/CEDO/SD/IRSOD/O	Oct, 2012	4, 8 and 10
10.	2011/CEDO/SD/IRSOD/Elect./02	Nov, 2012	6, 7, 8, 14, 27, 28, 32 and 38
11.	2012/CEDO/SD/IRSOD/O/01	Dec, 2012	12
12.	2013/CEDO/SD/IRSOD/O/01	May, 2013	10
13.	2011/CEDO/SD/IRSOD/Elect./02	Oct, 2013	6, 7, 8, 14 and 32
14.	2012/CEDO/SD/IRSOD/O/03	Nov, 2013	19, 20, 21, 23, 25
15.	2011/CEDO/SD/IRSOD/Elect./02	June, 2014	14
16.	2015/CEDO/SD/IRSOD/O/01	May., 2015	10 and 14
17.	2015/CEDO/SD/IRSOD/O/01	Aug, 2015	10
18.	2012/CEDO/SD/IRSOD/O	Nov, 2016	4
19.	2012/CEDO/SD/IRSOD/O(Pt.)	Nov., 2016	10
20.	2011/CEDO/SD/IRSOD/Elect./02(Pt.II)	July, 2017	7 and 8
21.	2012/CEDO/SD/IRSOD/O/ACS-21	Sept, 2017	28

Vimh

22.	2011/CEDO/SD/IRSOD/O/1	Dec, 2017	6, 7, 14, 12
23.	2011/CEDO/SD/IRSOD/O/2	Dec, 2017	12
24.	2017/CEDO/SD/IRSOD/O/2	Aug, 2018	12
25.	2018/CEDO/SD/IRSOD/ACS	Nov, 2018	04
26.	2017/CEDO/SD/IRSOD/O/ACS-83 rd TSC	Jan, 2019	4, 6, 9, 10, 14, 20, 22, 25
27.	2019/CEDO/SD/IRSOD/O/ACS-27	July, 2019	4, 10, 12, 21, 25, 28
28.	2019/CEDO/SD/IRSOD/ O/ACS-27	July, 2019	10
29.	2019/CEDO/SD/IRSOD/ O/ACS-27	May, 2020	10
30.	2020/CEDO/SD/IRSOD/ O/ACS-30	Feb, 2021	4, 6, 10, 14
31.	2021/CEDO/SD/IRSOD/ O/ACS-a	Oct, 2021	30, 31, 32
32.	2021/CEDO/SD/IRSOD/ O/ACS_b	Oct, 2021	10

Vimh

DIAGRAM No. 1A
1676mm GAUGE

STANDARD DIMENSIONS FOR TUNNELS & THROUGH GIRDER BRIDGES
SCHEDULE I - CHAPTER I

- NOTE:-**
1. WHERE THE LINE IS ON A CURVE, THE HORIZONTAL DISTANCE OF ANY STRUCTURE FROM THE CENTRE OF ADJACENT TRACK AND THE DISTANCE BETWEEN CENTRES OF TRACKS ARE TO BE INCREASED ACCORDING TO THE APPENDIX.
 2. WHEN RE-SPACING EXISTING LINES, THE MINIMUM DISTANCE CENTRE TO CENTRE OF TRACKS MAY BE REDUCED FROM 4725 TO NOT LESS THAN 4495 FOR THE PURPOSE OF AVOIDING HEAVY ALTERATIONS TO TUNNELS OR THROUGH GIRDER BRIDGES. THE 4725 DIMENSION IS TO BE ADOPTED FOR ALL NEW WORKS.

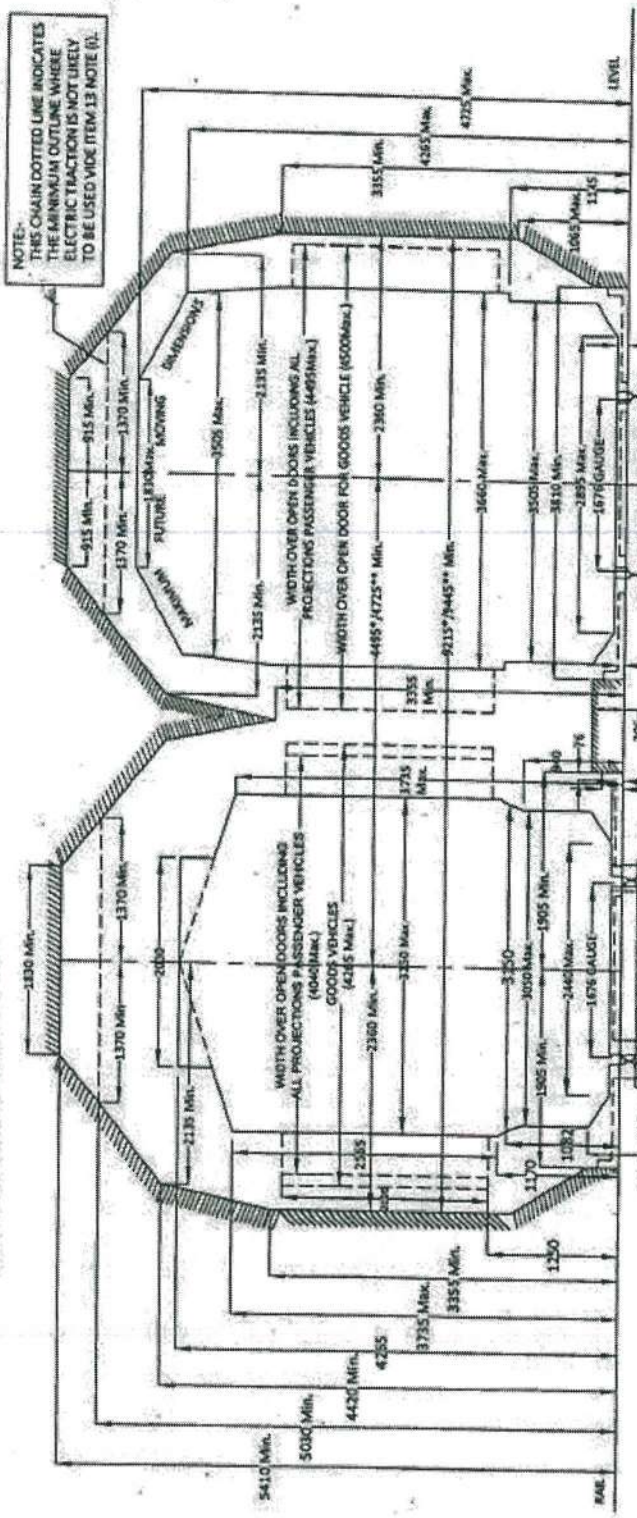

NOTE:- * - For existing works
** - for new works or alteration to existing works

NOTE:- ALL DIMENSIONS ARE IN MILLIMETRES EXCEPT WHERE OTHERWISE SHOWN.

Vimk

DIAGRAM No. 1A (MODIFIED)
1676 mm GAUGE

**STANDARD DIMENSIONS FOR TUNNELS & THROUGH GIRDER BRIDGES
 TO SUIT 25 K.V. A.C. TRACTION SCHEDULE I CHAPTER I**

NOTE:- THE DISTANCES SPECIFIED APPLY ONLY IN CASE OF STRAIGHT TRACKS. ON CURVES, THE HORIZONTAL DISTANCE SHOULD BE INCREASED BY AN AMOUNT 'D' TO ALLOW FOR THE LEAN DUE TO SUPER-ELEVATION CALCULATED BY THE FOLLOWING FORMULA, WHERE 'H' IS THE HEIGHT OF THE CONTACT WIRE, 'S' THE SUPER-ELEVATION AND 'G' THE GAUGE OF THE TRACK, ALL DIMENSIONS BEING IN METRES $D = H \times S / G$

NOTE:- THIS CHAIN DOTTED LINE INDICATES THE MINIMUM OUTLINE WHERE ELECTRIC TRACTION IS NOT LIKELY TO BE USED WIDE ITEM 13 NOTE (I) OF CHAPTER I SCHEDULE I.

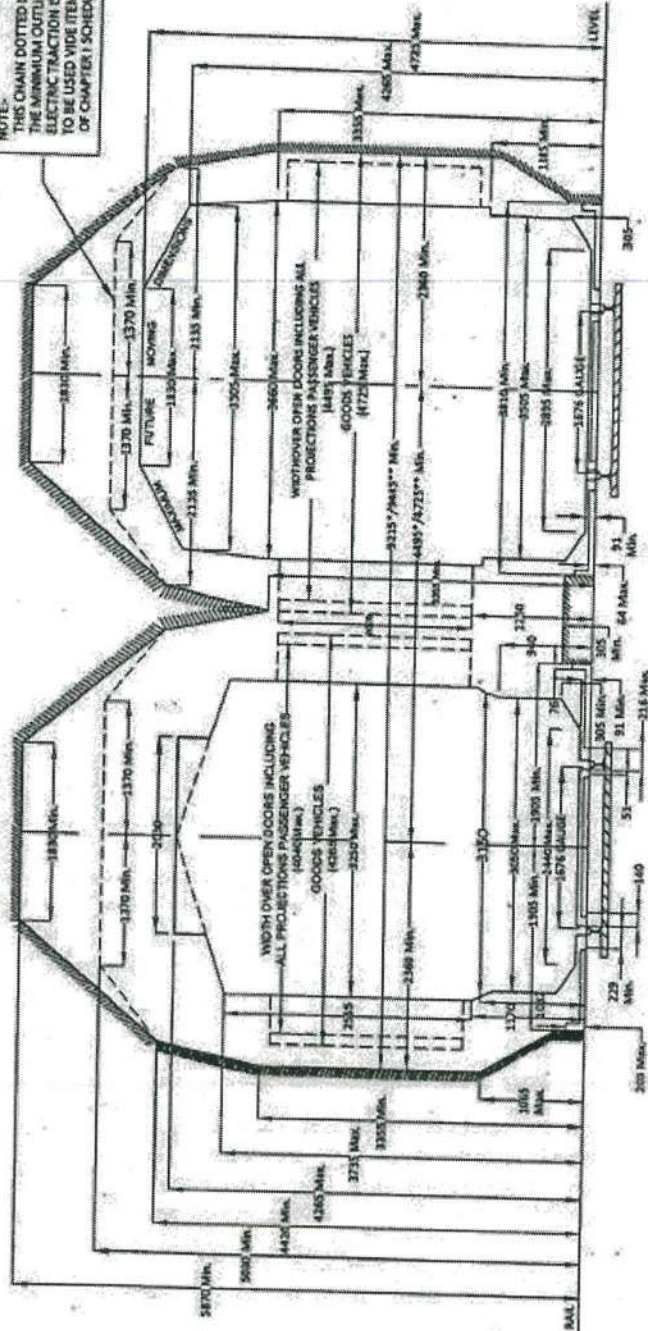

NOTE:-
 * For existing works
 ** For new works or alteration to existing works

NOTE:- ALL DIMENSIONS ARE IN MILLIMETRES EXCEPT WHERE OTHERWISE SHOWN.

Vimh

DIAGRAM N° 1. 1B
1676 mm GAUGE

STANDARD DIMENSIONS OUT OF STATIONS
SCHEDULE I - CHAPTER I

NOTE:- WHERE THE LINE IS ON A CURVE, THE HORIZONTAL DISTANCE OF ANY STRUCTURE FROM THE CENTRE OF ADJACENT TRACK AND THE DISTANCE BETWEEN CENTRES OF TRACKS ARE TO BE INCREASED ACCORDING TO THE APPENDIX.

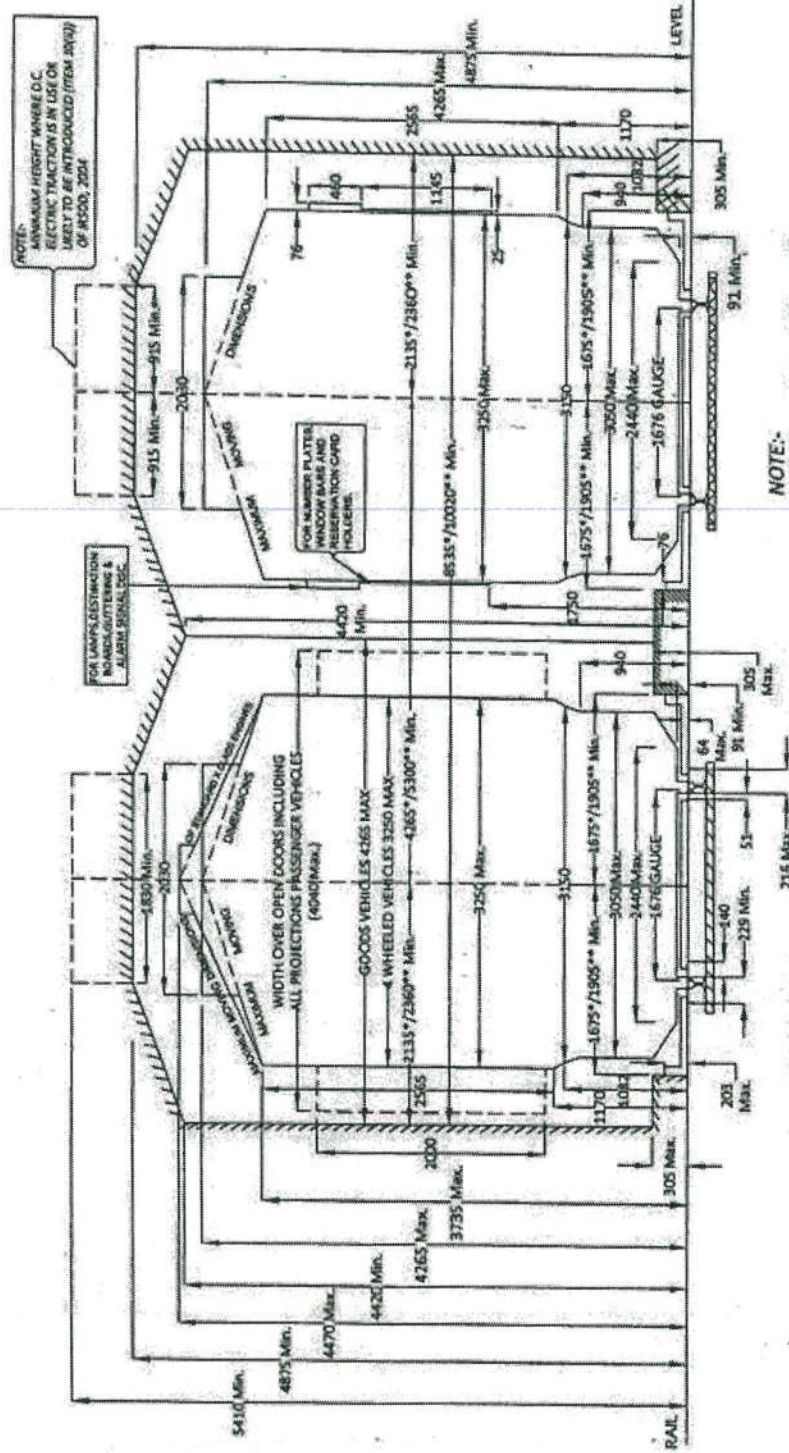

NOTE:-
* - For existing works
** - For new works or alteration to existing works

NOTE:- ALL DIMENSIONS ARE IN MILLIMETRES EXCEPT WHERE OTHERWISE SHOWN.

Vimk

STANDARD DIMENSIONS OUT OF STATIONS

DIAGRAM No. 1C
1676 mm GAUGE

TO SUIT 25 KV. A.C. TRACTION
SCHEDULE I - CHAPTER I

NOTE: THE DISTANCES SPECIFIED, APPLY ONLY IN CASE OF STRAIGHT TRACK. ON CURVES, THE HORIZONTAL DISTANCE SHOULD BE INCREASED BY AN AMOUNT 'D' TO ALLOW FOR THE LEAN DUE TO SUPER-ELEVATION CALCULATED BY THE FOLLOWING FORMULA, WHERE 'H' IS THE HEIGHT OF THE CONTACT WIRE, 'S' THE SUPER-ELEVATION AND 'G' THE GAUGE OF THE TRACK, ALL DIMENSIONS BEING IN METRES. $D = \frac{H \times S}{G}$

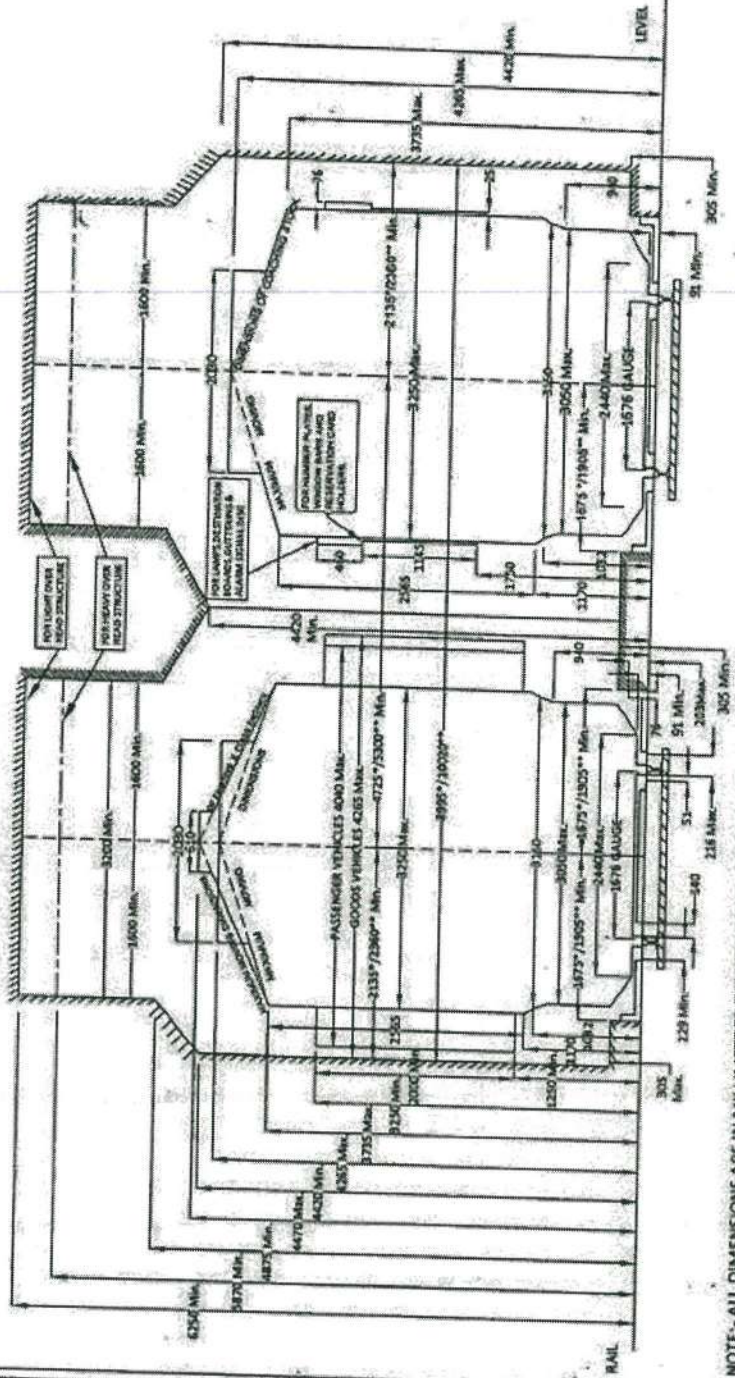

NOTE:- ALL DIMENSIONS ARE IN MILLIMETRES EXCEPT WHERE OTHERWISE SHOWN.

NOTE:- * - For existing works
** - For new works or alteration to existing works

Vimh

DIAGRAM No. 1D
(EDO/T-2202)
1676mm GAUGE

MAXIMUM MOVING DIMENSIONS

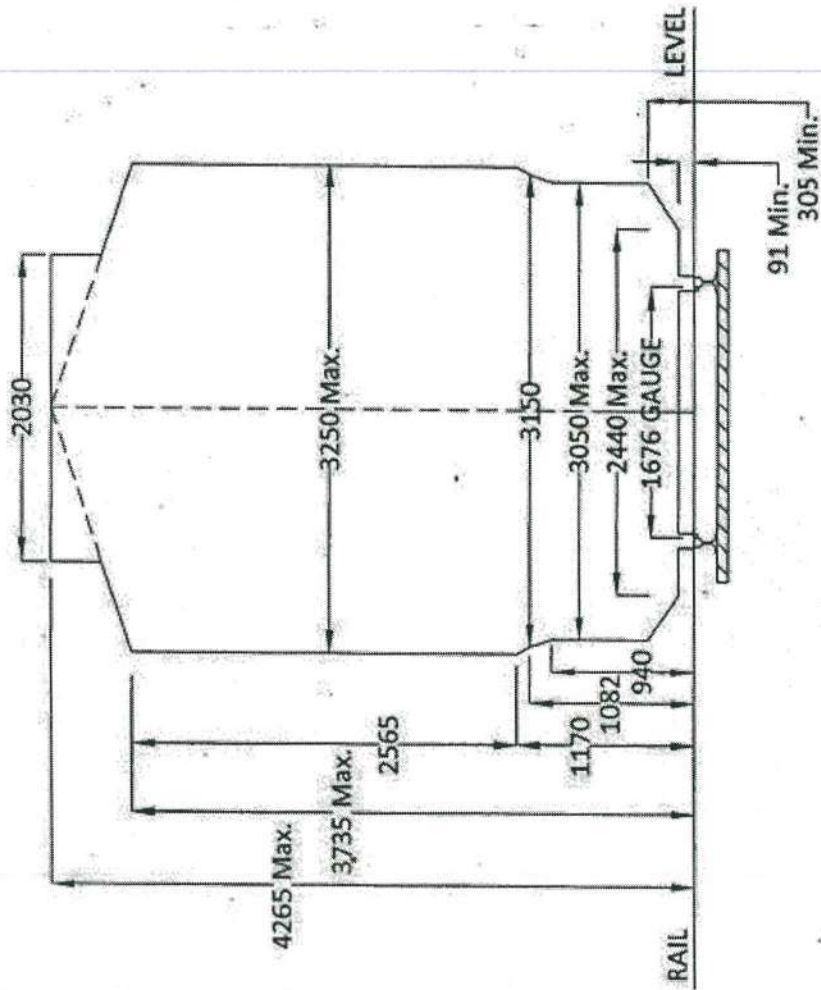

NOTE:- ALL DIMENSIONS ARE IN MILLIMETRES EXCEPT WHERE OTHERWISE SHOWN.

Vimk

DIGRAM NO. 3 (FIG 1)
1676mm GAUGE

INFRINGEMENTS OF SCHEDULE - I

FOR 3660 mm GOODS STOCK & NEW
STANDARD LOCOMOTIVES IN EXISTING
BRIDGES ONLY

PERMITTED UNDER SCHEDULE-II
MINIMUM CLEARANCES ON EXISTING GIRDER BRIDGES

NOTES:-
FULL LINES SHOW MAXIMUM MOVING DIMENSIONS OF
FUTURE 3660 WIDE STOCK & OF EXISTING 3202/2250 WIDE
STOCK & OUTLINE OF EXISTING 3660 WIDE ELECTRIFIED
STOCK. DOTTED LINES SHOW OUTLINE OF NEW STANDARD
A.E. & W.A. ENGINES & OF PROPOSED 3669 WIDE HIGH
SIDED OPEN TRUCK.

FULL HATCHED LINES SHOW DIMENSIONS WHICH SHOULD
NOT BE INFRINGED IN TUNNELS, DOTTED HATCHED LINES
SHOW DIMENSIONS WHICH SHOULD NOT BE INFRINGED
ON GIRDER BRIDGES WHERE THE TRACK IS TIED TO
THE GIRDERS.

THE MINIMUM PERMISSIBLE CLEARANCES WILL BE
(1) UNDER ANY CIRCUMSTANCES & SUBJECT TO ANY RESTRICTION OF SPEED
WHICH IT MAY BE CONSIDERED NECESSARY TO IMPOSE.

IN TUNNELS

- AT A --- 229mm
- AT B --- 305mm
- AT C --- 388mm
- AT D --- 229mm

ON GIRDER BRIDGES

- AT A --- 229mm (AT TOP OF SIDES OF VEHICLES)
- AT B --- 229mm (AT SIDES OF VEHICLES)
- AT C --- 305mm (BETWEEN MOVING TRAINS)
- AT D --- 152mm (ABOVE VEHICLES)

(2) FOR UNRESTRICTED SPEED.

IN TUNNELS

- AT A --- 380mm
- AT B --- 535mm
- AT C --- 610mm
- AT D --- 305mm

ON GIRDER BRIDGES

- AT A --- 229mm (AT TOP OF SIDES OF VEHICLES)
- AT B --- 85mm (AT SIDES OF VEHICLES)
- AT C --- 535mm (BETWEEN MOVING TRAINS)
- AT D --- 229mm (ABOVE VEHICLES)

WHERE DOORS OPENING INWARDS OR OF THE RECESSED
OR SLIDING TYPE ARE PROVIDED, THE MINIMUM CLEARANCE IN
TUNNELS & BRIDGES MAY BE REDUCED TO 380 AT B & 465
AT C FOR UNRESTRICTED SPEED.

TO THE ABOVE MUST BE ADDED THE EXTRA ALLOWANCES FOR CURVES (SEE APPENDIX.)

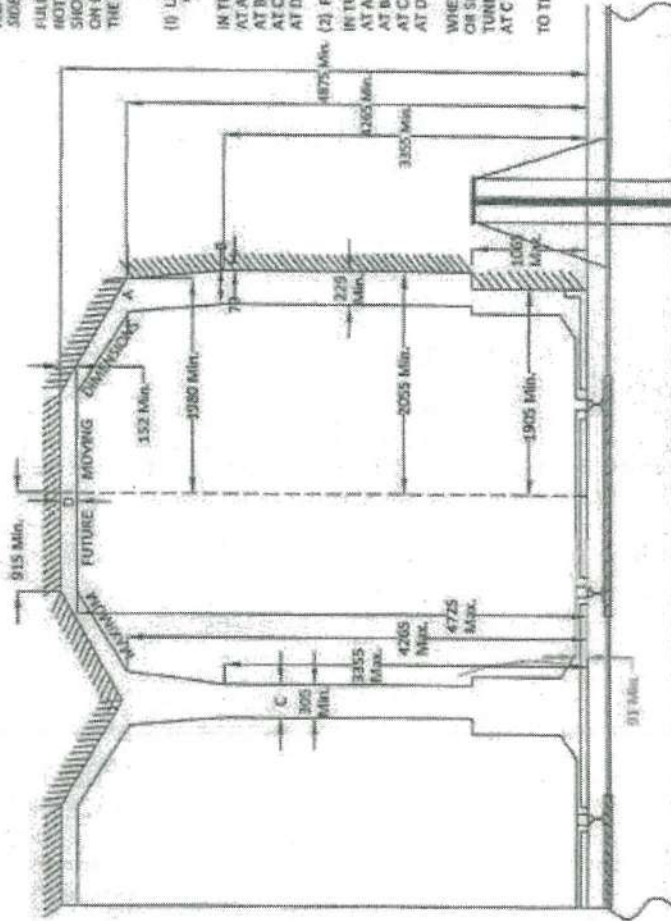

NOTE:- ALL DIMENSIONS ARE IN MILLIMETRES EXCEPT WHERE OTHERWISE SHOWN.

Vink

DIAGRAM NO. 4
1676mm GAUGE

MAXIMUM MOVING DIMENSIONS OF 1929 PROFILE

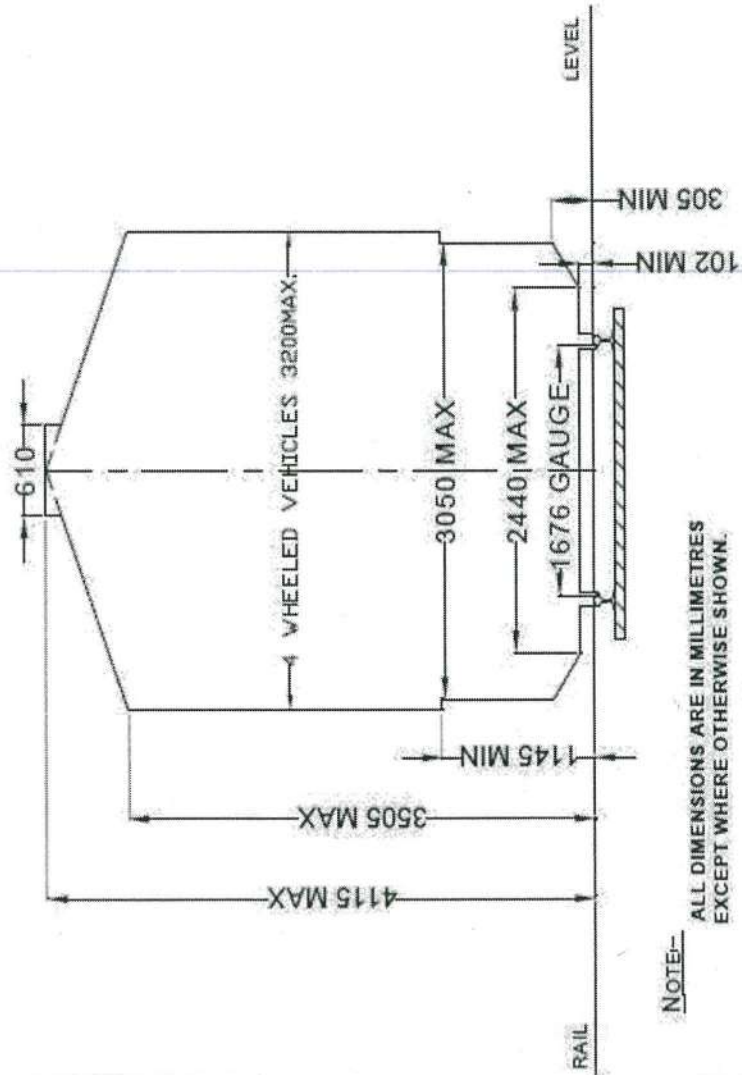

NOTE:-
ALL DIMENSIONS ARE IN MILLIMETRES
EXCEPT WHERE OTHERWISE SHOWN.

Vink

Annexure B- Payload to Tare ratio of some of the Wagons currently running on IR

SN	Wagon	Axle Load (in t)	Values given are in Tonnes		Payload to Tare Weight Ratio
			Tare Weight	Payload	
	OPEN				
1	BOXNHL	22.9	20.6	71	3.45
2	BOSTHS	22.32	25.5	63.78	2.50
3	BOXNS	25	20	80	4.00
	COVERED				
4	BCNAHS	22.82	24.6	66.7	2.71
5	BCNHL	22.9	20.8	70.8	3.40
	HOPPER				
6	BOBRNHS	22.32	25.61	63.67	2.49
7	BOBYNHS	22.9	25.2	66.4	2.63
8	BOBSN	22.9	30	61.6	2.05
	FLAT				
9	BRN22.9	22.9	23.3	68.3	2.93
10	BFNSM	22.9	22	69.6	3.16
11	BFNV	22.9	22	69.6	3.16
	COVERED HOPPER				
12	BCFCM	22.9	23.1	68.2	2.95
	Container Wagon				
13	BLC (A/B)	20.32/20.32	19.1/18.0	61/61	3.19/3.39
14	BLCM (A/B)	22/22	19.1/18.0	68.9/70	3.61/3.89
15	BLCS (A/B)	25/25	19.2/18.1	80.8/81.9	4.21/4.52
	Autocar Wagon				
16	BCACBM (A/B)	12.71/12.68	35.86/35.72	15/15	0.42/0.42

Vinik

Annexure B1- Rake Composition of Different types of Wagons on Indian Railways

SN	Type of wagon	Number of wagons in a rake	Length of one wagon over couplers (in mm)
1.	BOXN/BOXNLW/BOXNR/BOXNEL/ BOXNHA/BOXNS	59	10713
2.	BOXNHL	58	10963
3.	BOST	46	13729
4.	BOY/BOYEL	52	11929
5.	BCFC/ BCFCM/ BCCW	59	10713
6.	BCN	41	15429
7.	BCNA	44	14450
8.	BCNHL	58	10963
9.	BOBRN	58	10600
10.	BOBR	54	11600
11.	BOBYN	54	11647
12.	BOBSN	54	11597
13.	BCBFG	49	12790
14.	BTAPM1	51	12329
15.	BCACM	45 (18+27)	14566/13165
16.	BCACBM	27	23555
17.	BTPN/BTFLN/BTFLNM1	47 (585 meter)	12420
18.	BTALNM/BTALNM1	33 (585 meter)	17529
19.	BTCS	54 (585 meter)	10713
20.	BTPGLN	30 (585 meter)	18929
21.	BTPH	45 (585 meter)	12929
22.	BRN/BRNM1/BRN22.9 & BRN22.9M1/ BRNA/BRNAHS/BRNAM1/BFNS & BFNS22.9	43	14645
23.	BFNSM22.9/BFNV	58	10963
24.	BLCA/BLCB/BLCAM/BLCBM	45(18+27)	14566/13165
25.	BLLA/BLLB	40(16+24)	16161/14763
26.	BLCSA/BLCSB	45(18+27)	14554/13141
27.	BFKN	40	14645

Vink

Annexure C-Terms & Conditions for Licensing/Providing access to Maintenance Facility of IR to WD

1. IR may license one of its Maintenance facilities for undertaking maintenance of NWD by WD, if spare capacity is available.
 - 1.1. Such licensing to separate areas in one maintenance facility can be given to more than one WD, till such time infrastructure is utilized to its capacity. It will be called "Common User Facility".
 - 1.2. Maintenance facility may include land, track, building, M&P or Part thereof.
 - 1.3. Such licensing will be given for a period of five years, which may be renewed every 5 years upto the period of agreement. During such renewal, license fee can also be reviewed. Licensing of vacant spareable Land and Building in Railway's maintenance facility for the purpose of undertaking maintenance of wagon will be governed as per the extant policies of license of land and building respectively.
 - 1.4. Valuation for such maintenance facility shall be done and accordingly a fixed license fee as per extant policy shall be charged.
 - 1.5. Any upgrade of infrastructure for undertaking maintenance work of NWDs at such facility shall be the responsibility of WD. Fixed infrastructure so created will become property of IR, upon termination of license period.
 - 1.6. Maintenance of building, track, OHE & Signalling handed over by IR to the WD shall be done by IR at its own cost. However, maintenance of Machinery & Plant handed over by IR and the additional infrastructure created by WD shall be done by WD at its own cost.
2. IR may also provide access to one of its Maintenance facilities for undertaking maintenance (yard examination, major schedules and out of course repair) of NWD by WD, if spare capacity is available.
 - 2.1. Such access shall be provided for a period of three years from the date of issue of clearance for unrestricted introduction of NWD on IR
 - 2.2. Material, labour, M&P (other than those mentioned for yard examination in para 2.3 below) and tools required for maintenance shall be arranged by the WD on his own cost.
 - 2.3. A lumpsum fee of Rs 25,000/-for minimum six hours (if time taken exceeds six hours, charges to be proportionately increased) for examination in yard of one rake of NWD shall be charged, which shall include: access to track nominated for examination, cost of electricity, compressed air, rake test rig, lighting (as provided in the yard line) and water. These charges can be reviewed after every 5 years.
 - 2.4. For major schedules (ROH/POH) and out of course repair, total maintenance area of 500 m² consisting of approx. 50 m track length with 7 meter width (covered or in the open) and 150 m² space (built up or open) for storage of equipment can be assigned to one WD, subject to availability,

Vinik

at a lumpsum cost of Rs 2,000/- per day. These charges can be reviewed after every 5 years. This cost will include lighting if already provided in the area and water supply, as needed. In case total area required is more than 500 m², cost will be calculated on prorata basis. Cost of electricity consumed for maintenance will be extra for which separate electric meter will be installed by IR.

3. Access for movement of manpower, material, M&P of WD inside the shed/yard and between the maintenance and storage area shall be facilitated by IR.
4. Special assistance like wheel turning and wheel pressing (re-discing) can be provided by IR on chargeable (on rates given in Annexure-D) and best-efforts basis.
5. WD shall ensure safety during maintenance in IR's facilities, as applicable, and shall also be responsible for any obligation arising out of it, for which necessary insurance shall be taken by WD, as mentioned in clause 16 of the main policy.
6. Maintenance facility (land/building/etc.) of IR being given under licensing/access shall not be utilized by WD for any purpose other than maintenance of New Wagon Designs. In case any deviation in this regard is noticed at any time, licensing/access given to WD is liable to be cancelled.

Vishu

Annexure D- Charge for some of the Unique activities related to Wagon Maintenance

SN	Activity	Unit Rate (in Rs)
1.	Re-profiling (turning) of Wheel discs of one Wheelset- Machine, labour and consumables only	3000
2.	One Wheel disc changing- Machine, labour and consumables only (excluding cost of wheel disc, which shall be supplied by the WD)	6000
3.	One axle UST - Machine, labour and consumables only	1000

Note: These charges can be reviewed after every 5 years

Vimh